

OWNERS' HANDBOOK
FOR
OPERATION AND MAINTENANCE
OF
THE PIPER SUPER-CUB

Models PA-18—95, PA-18—150
and PA-18A—150



PIPER AIRCRAFT CORPORATION, LOCK HAVEN, PA.

OWNERS' HANDBOOK
FOR
OPERATION AND MAINTENANCE
OF
THE PIPER SUPER-CUB

Models PA-18—95, PA-18—150
and PA-18A—150

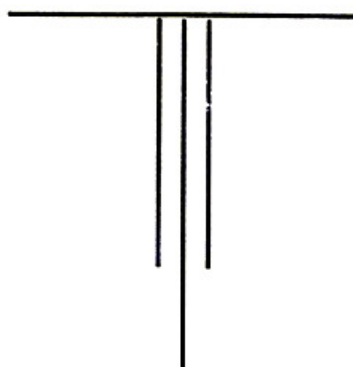

PIPER AIRCRAFT CORPORATION, LOCK HAVEN, PA.

TABLE OF CONTENTS

VOLUME ONE—The PA-18

SECTION ONE	Page
Design Features -----	7
I. Specifications -----	7
II. Power Plant and Propeller -----	8
III. Fuselage and Wings -----	9
IV. Landing Gear -----	11
V. Empennage -----	11
VI. Control System -----	11
VII. Fuel System -----	13
VIII. Electrical System -----	15
IX. Finish -----	15
X. Cabin Features -----	17

SECTION TWO

Operating Instructions -----	19
I. Flight Procedure -----	19
1. Starting -----	19
2. Warm-up and Ground Check -----	19
3. Take-off, Climb, and Stalls -----	21
4. Cruising -----	21
5. Approach and Landing -----	22
6. Weight and Balance -----	23

SECTION THREE

General Maintenance -----	24
I. Leveling and Rigging -----	24
II. Tire Inflation -----	25
III. Battery Service -----	25
IV. Brake Service -----	25
V. Fuel Requirements -----	26
VI. Care of Windshield and Windows -----	27
VII. Landing Gear Service -----	27

SECTION FOUR

Inspections -----	28
-------------------	----

SECTION FIVE

Warranty -----	38
----------------	----

VOLUME TWO—The PA-18A

SECTION ONE

General Design -----	41
----------------------	----

SECTION TWO	
Description of the Dispersal Unit	42
SECTION THREE	
Operation of the Spray Unit	43
SECTION FOUR	
Operation of the Dust Unit	47
SECTION FIVE	
Original Installation of the Dispersal Units	48
Spray Unit	48
Dust Unit	51
SECTION SIX	
Conversion of the Combination Unit	52
SECTION SEVEN	
Conversion to Two-Place Model	53
SECTION EIGHT	
Conversion to Cargo Model	53
Spray Output Table—Low Volume Unit	54
Spray Output Table—High Volume Unit	55

PICTURES AND ILLUSTRATIONS

	Page
Figure 1—The PA-18	6
Figure 2—Landing Gear	8
Figure 3—Aileron and Elevator Controls Model PA-18	10
Figure 4—Rudder and Flap Controls Model PA-18	12
Figure 5—Electrical System Diagram Model PA-18	14
Figure 6—Fuel System Model PA-18	16
Figure 7—Empennage	18
Figure 8—Fuel Consumption	20
Figure 9—Cargo Area	23
Figure 10—The PA-18A	40
Figure 11—Spray Unit Installation	46
Figure 12—Venturi Installation	46

PREFACE

THE PIPER SUPER CUB is a versatile high performance airplane, designed to provide the maximum in utility, efficiency and safety. Because of its unusual design and performance, it is in fact a replacement for many types of ground machines. It is available in two models of the basic design, the 90 H. P. Continental version and the 150 H. P. Lycoming version of the Standard PA-18. It is also available in a specialized agricultural version, the PA-18A with the Lycoming 150 engine.

This owner's handbook has been compiled to provide a convenient source of information on the operation and maintenance of all of these Super Cub models and to help the owner obtain the utmost in pleasure and utility in the use of his airplane.

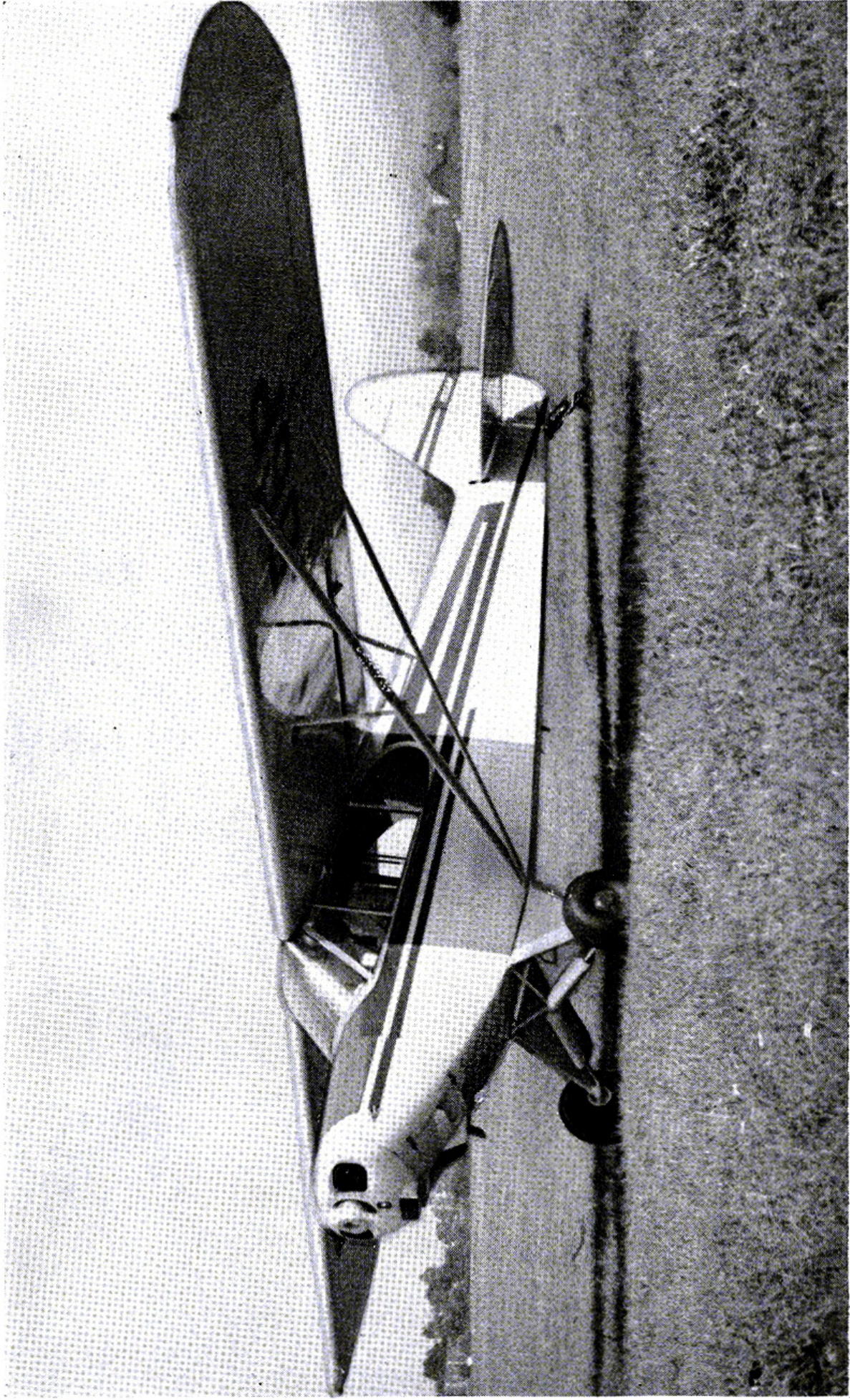

Figure 1

SECTION ONE

DESIGN FEATURES

I. SPECIFICATIONS:

	"95"	"150"
Engine -----	Cont. C-90	Lyc. 0-320
HP and RPM -----	90 at 2475	150 at 2700
Gross Weight (lbs.) -----	1500	1750
Empty Weight (Standard) (lbs.) -----	800	930
Useful Load (lbs.) -----	700	820
Wing Span (ft.) -----	35.3	35.3
Wing Area (sq. ft.) -----	178.5	178.5
Length (ft.) -----	22.4	22.5
Height (ft.) -----	6.7	6.7
Prop Diameter (max. in.) -----	74	74
Power Loading -----	16.6	11.6
Wing Loading -----	8.4	10
Baggage Capacity -----	50	50
Fuel Capacity -----	18	36
Tire Pressure (lbs./sq. in.) -----	18	18

Performance

	"95" Wood Prop	"95" Std. Metal Prop	"150" Metal Prop 1750 lbs.	"150" Metal Prop 2070 lbs.*
Top Speed (mph) -----	110	112	130	128
Cruising Speed (75% power mph) -	100	100	115	113
Stalling Speed (mph) -----	42	42	43**	45**
Take-off Run (ft.) -----	452	390	200**	300**
Take-off over 50' barrier (ft.) -----	952	750	500**	950**
Landing Roll (ft.) -----	385	385	350**	410**
Best Rate of Climb Speed (mph) --	71	71	75	75
Rate of Climb (ft./min.) -----	624	710	960	760
Best Angle of Climb Speed (mph) -	63.5	63.5	45	55
Best Angle of Climb (ratio) -----	1 to 9.4	1 to 8	1 to 5	1 to 9
Service Ceiling -----	13,500	15,750	19,000	17,000
Absolute Ceiling -----	16,000	17,750	21,300	19,000
Fuel Consumption				
(gal./hr.) (75% power) -----	5	5	9	9
Cruising Range (75% power) -----	360	360	460	460

* Gross weight over 1,750 lbs. is now permitted for special purpose uses under Part 8 of CAR.

** Flaps extended.

Performance figures are for airplanes flown at gross weight under standard conditions at sea level.

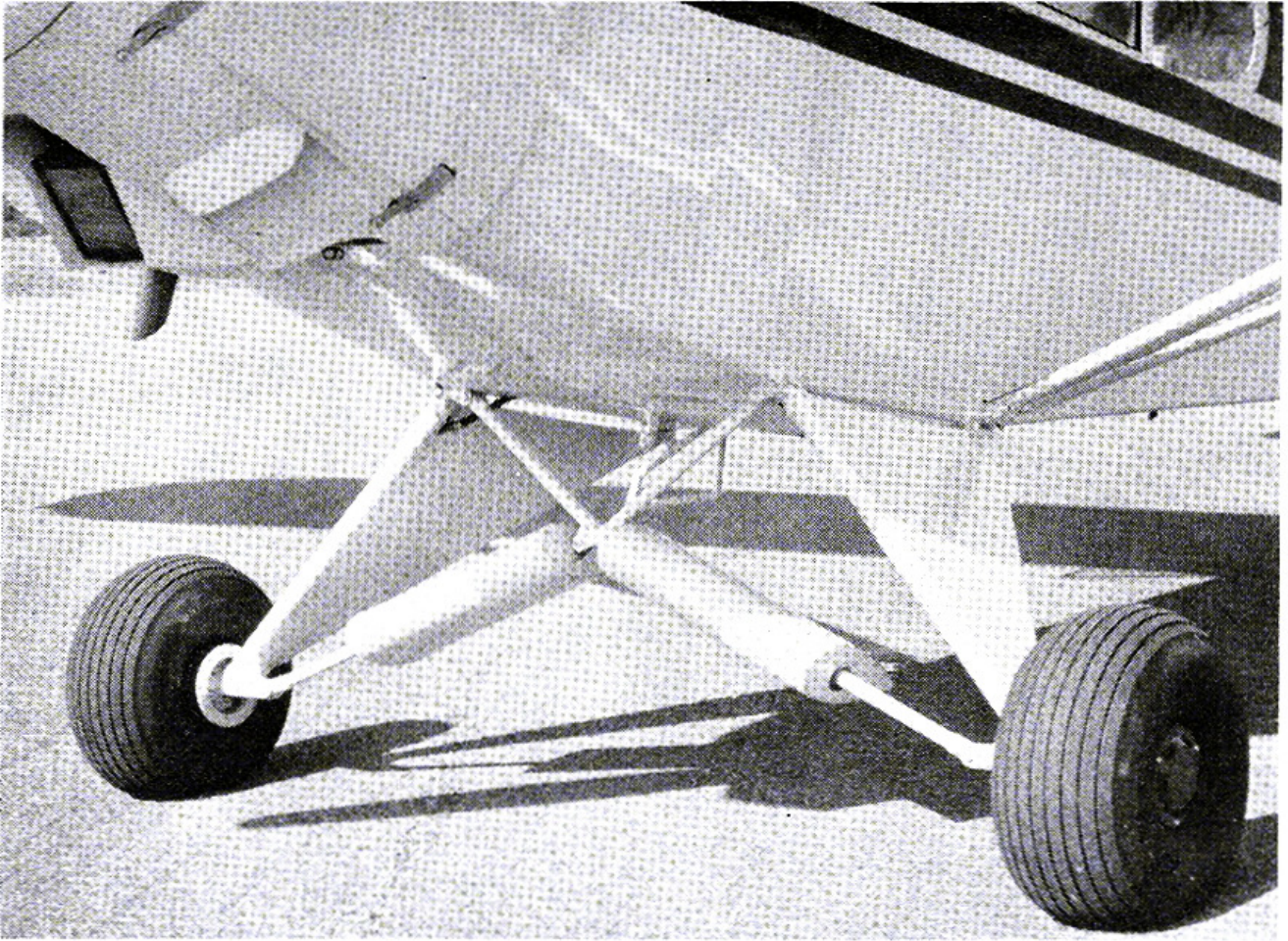

Figure 2

II. POWER PLANT AND PROPELLER:

The Super Cub "95" is powered with a Continental C-90-8F engine or a C-90-12F if starter and generator (optional equipment) are installed. These engines are rated at 90 H. P. at 2475 R. P. M.

The Super Cub "150" is powered with a Lycoming O-320 engine, with a rated horsepower of 150 at 2700 R. P. M. The standard installation of this engine is also without electrical system, which is available optionally.

The steel tubular engine mount on the Super Cub models is mounted to the fuselage at the firewall on hinges, so that the rear of the engine can readily be made accessible for service. To hinge the motor mount, first remove the top, side and bottom engine cowl panels, which are quickly detachable by means of cowl fasteners. Next detach the rear end of the cowl support channels from their firewall brackets, extract the right hand hinge bolts, disconnect the tachometer shaft at the engine and swing the right side of the engine forward until the stop mechanism is extended.

The standard propeller on the Super Cub "95" is the Sensenich wood propeller design 72-GK-50. A Sensenich metal propeller design 76-AN-242 is available as optional equipment. On the "150", the standard propeller is the Sensenich metal design 74DM56. In general, propeller designs selected for the Super Cub models emphasize take-off, climb and economical cruising performance rather than high speed cruising. If propellers with higher pitches are used, the cruising speed can be increased somewhat.

A stainless steel cross-over exhaust system is employed on the "150" to scavenge exhaust gasses effectively. This permits the use of an efficient muffler without any loss in engine power output due to exhaust backpressure. The muffler is shrouded to provide sources of heat for the cabin and carburetor heating systems.

III. FUSELAGE AND WINGS:

The fuselage frame of the Super Cub is constructed of steel tubes welded together to form a rigid structure. A number of highly stressed members are of chromemolybdenum steel (4130). Other members are of 1025 steel.

Repairs to the fuselage can be made in the manner approved by the Civil Aeronautics Authority Manual No. 18, and repair facilities for this type of construction are available universally.

The fuselage is made corrosion resistant by the application of a coat of zinc chromate, followed by a sealer coat of nitrate dope. A third coat of dope proof lacquer is sprayed on the fuselage members wherever fabric comes in contact with the structure. If the airplane is to be used in salt water areas, the fuselage can be metalized prior to applying the zinc chromate and dope; at the same time the interior of the tubing is coated with linseed oil to prevent internal corrosion.

The wing framework consists of riveted aluminum ribs mounted on extruded aluminum spars with tubular drag and compression struts and high strength stainless steel drag wires. Aluminum sheet is used to form the leading edge and the aileron false spar. An ash wing tip bow provides a light tough member which can withstand considerable wing tip shock without failing.

The wings are attached to the fuselage at the wing hinge fittings on upper fuselage members, and by means of the lift struts which bolt to the lower fuselage members and to the wing spar fittings. The lift struts can be adjusted in length by turning in or out the forked fittings at the lower ends. This adjustment is used to set the rigging

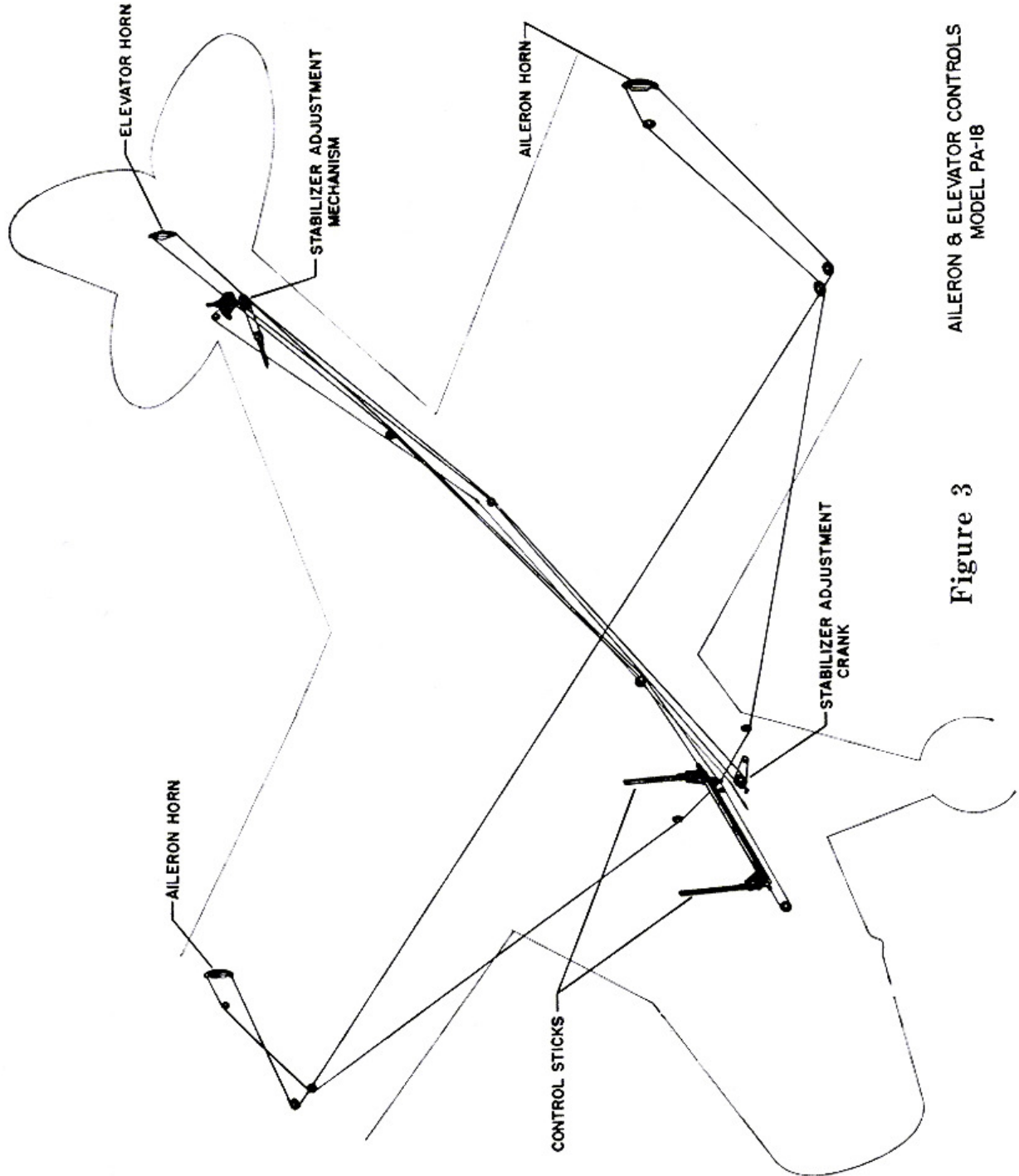

AILERON & ELEVATOR CONTROLS
MODEL PA-18

Figure 3

of the wings. Any lifting of the airplane at the struts should be done at the extreme end of the strut and not in the center, to prevent bending the struts.

IV. LANDING GEAR:

The Super Cub landing gear is the well proven maintenance-free-shock cord type, which employs two 8"x $\frac{3}{4}$ " shock rings on each shock strut. The only maintenance required on this gear is occasional greasing of the hinge bolts and shock strut members, and inspection of the steel hinge bolt bushings, which can be replaced if worn.

Hydrosorb shock units, which consist of automotive type oleo struts combined with light shock cords, are available optionally.

The Scott 2" steerable full-swivel tail wheel, model 3-24B is standard equipment on the Super Cubs. This tail wheel can be replaced with an 8" Scott model which provides greater floatation, provided that the tail wheel leaf springs are changed with the wheel. The standard tail wheel tire is 6:00x2 of the solid rubber type.

Main wheel assemblies are Goodrich D-3-13-A-1, on which are mounted 8:00x4 four ply tires. The tire inflation of 18 lbs. must be maintained reasonably constant to prevent tire slippage on the wheel and to produce even wear.

V. EMPENNAGE:

The units which make up the empennage are the Fin, Rudder, Stabilizers and Elevators. They are all constructed of tubular steel with steel channel ribs. The control surface hinges have bronze bushing inserts and should be oiled with light oil occasionally. Stainless steel tie rods brace the stabilizer to the fin and fuselage. The tail brace wires should not be used for lifting or handling the airplane.

Although the fin and rudder are identical on both models of the PA-18, the stabilizers and elevators are different in that the Super Cub "150" has a larger span on the tail surfaces to provide extra longitudinal stability, and the elevators are designed with an aerodynamic balance to increase stability and reduce control forces. On the Super Cub "95" the tail surfaces are almost identical with those of preceding tandem models.

VI. CONTROL SYSTEM: (See Figures 3 and 4)

Conventional dual flight and engine controls are provided in the Super Cub. In the Model "150", which is equipped with flaps, the

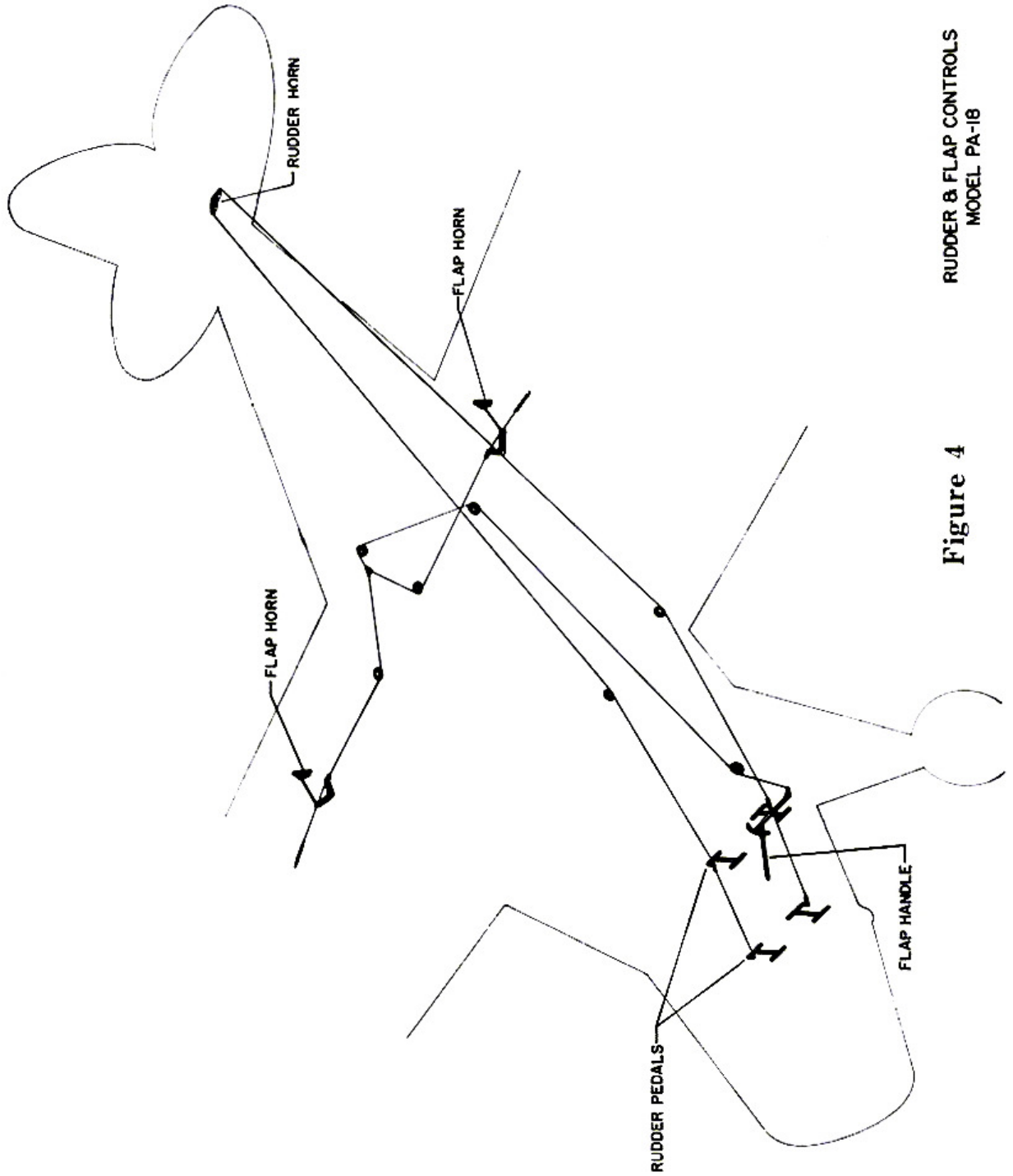

RUDDER & FLAP CONTROLS
MODEL PA-18

Figure 4

flap control is located for front seat operation only. Solo operation of both models is normally from the front seat although rear seat operation is entirely feasible.

The flap lever can be set in any one of three positions, for full up flap, half flap, or full down flap. Full flap is recommended for minimum speed landings. Half or full flap can be applied to reduce take-off run, the more flap used the shorter the run. A minimum take-off distance is obtained by beginning the take-off with flaps up, then applying full flaps when take-off speed (30-35 m. p. h.) has been reached. The best angle of climb is attained with full flap. The best rate of climb is without any flap extended.

The stabilizer adjustment crank is located on the left cabin panel adjacent to the front seat. A permanently automatic tension adjustment, which consists of an idler pulley held in place near the rear main pulley by a tension spring, maintains correct tension on the stabilizer cable and prevents cable slippage. This system normally requires no attention except for lubrication and inspection.

VII. FUEL SYSTEM:

An 18 gallon fuel tank located in the left wing is the main fuel supply for the Super Cub "95" in the standard installation. A second 18 gallon tank can be installed as optional equipment in the right wing. On the model "150", two 18 gallon tanks are standard equipment.

A small (approximately 2 quarts) header tank which serves to maintain constant fuel flow to the engine regardless of the normal attitude of the airplane, is included in the installation of each fuel tank. The header tank for the left or main fuel tank is located forward of the instrument panel, for the right tank is concealed behind the headlining aft of the rear seat.

Fuel indicator gauges are installed in the upper cabin panels and are easily discernible from either seat. The fuel shut-off valve is in the left cabin panel near the front seat.

The fuel strainer, on the lower left side of the firewall in the engine compartment, traps water or sediment that may collect in the fuel system and should be checked regularly. Fuel screens are provided at each tank outlet, in the strainer, and at the carburetor.

The engine primer pump on the right side of the instrument panel takes fuel from the top of the fuel strainer and pumps directly to all four cylinders on the engine. The primer should be locked in at all times except when in use to prevent malfunctioning of the engine.

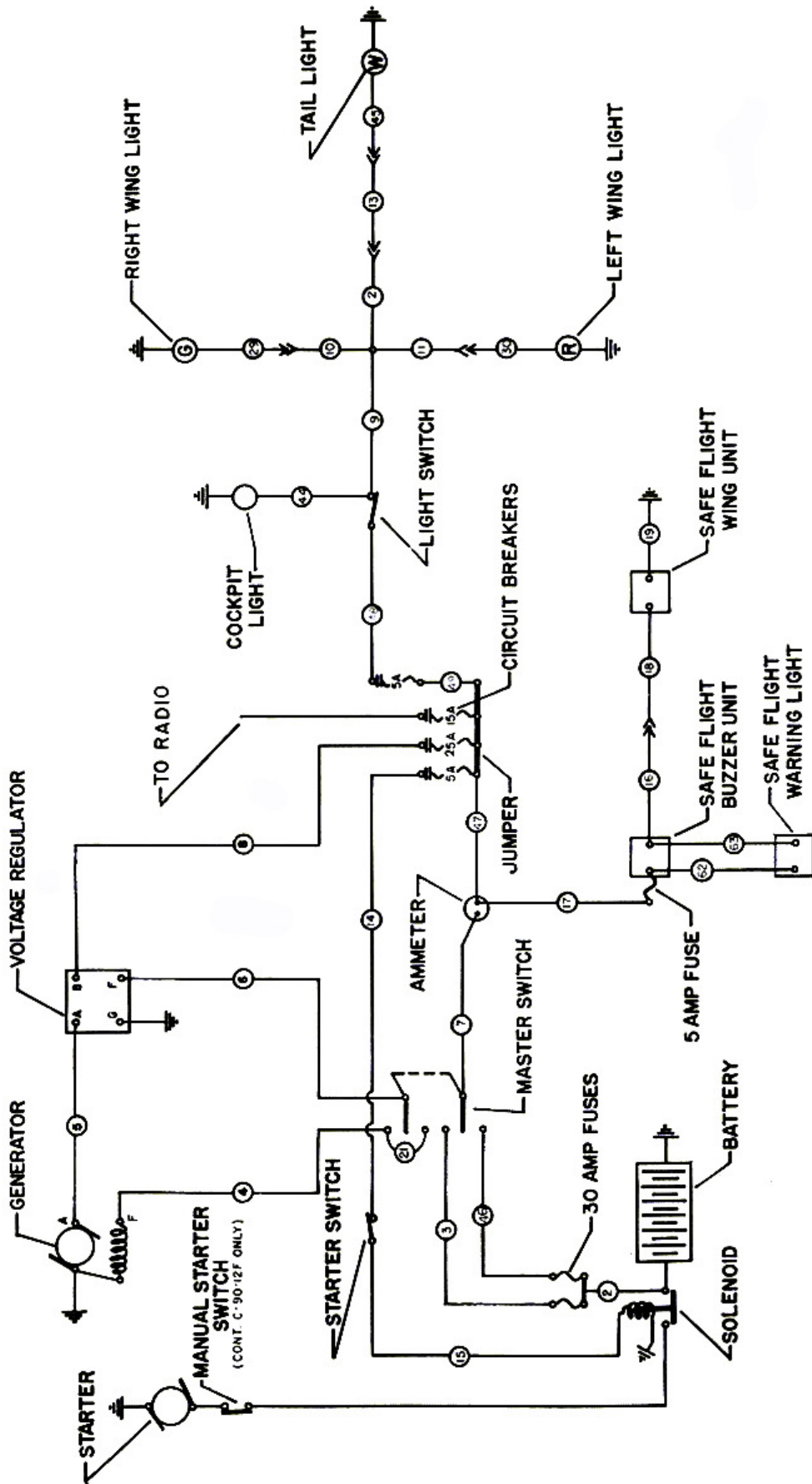

ELECTRICAL SYSTEM DIAGRAM
MODEL PA - 18

Figure 5

An idle cut-off is incorporated in the mixture control so that full extension of the control stops the flow of fuel at the carburetor. The cut-off should always be used to stop the engine.

In the two tank fuel system, it is recommended that the left tank be considered the main tank and that fuel be used from the right tank first on long flights, saving the left tank until the last. To get the maximum range, use the fuel from the right tank until the engine falters from lack of fuel, then switch to the left tank.

VIII. ELECTRICAL SYSTEM: (See Figure 5)

An electrical system, consisting of starter, generator, battery, voltage regulator, ammeter, starter solenoid, circuit breakers, fuses, switches and related wiring, is optional equipment on either model of the Super Cub.

A 12 volt Reading battery is mounted in the fuselage aft of the baggage compartment, and a master switch and circuit breaker panel on the cabin panel over the right door. The circuit breakers automatically break the electrical circuits if an overload is applied. To reset the circuit breakers simply push in the buttons. A continuous popping of the circuit breakers indicates a short and should be investigated.

The master switch is connected with a main and a spare fuse, located near the battery box. The starter solenoid is also mounted near this box.

A voltage regulator attached to the engine side of the firewall is incorporated in the system to maintain the required voltage of the battery. Position and instrument panel lights (extra equipment) are operated with the same switch on the electrical panel.

IX. FINISH:

The Duraclad finish on the Super Cubs consists of fire resistant butyrate plastic material on the fabric surfaces, and enamel on metal surfaces. Duraclad provides, in addition to the fire resisting qualities, a high-luster, more attractive finish which has a much longer life than earlier nitrate finishes.

All of the fabric, inside and outside, on the new models is treated with butyrate plastic. All of the exterior metal surfaces are finished with enamel. The Duraclad finish must not be covered over with any incompatible material. The use of different materials from those originally applied will damage the finish.

X. CABIN FEATURES:

The standard instrument group in the Super Cub includes the following: Altimeter, Airspeed, Compass, Oil Temperature and Pressure Gauge, and Tachometer. Special panels which provide complete instrumentation are available as optional equipment. A sensitive altimeter or recording tachometer is also available in the standard panel.

The front seat is adjusted fore and aft by depressing a lever on the left side of the seat frame. To remove the seat entirely, remove the forward stop pin on the left rear corner, then release the adjustment lever and slide the seat forward off its mounting channels.

To increase the space available for cargo carrying, the rear seat back can be easily removed. First pull out the spring clips at the top of and behind the seat back, which hold the seat back in place. Then lift the back out of its lower sockets.

Shoulder harness kits are available for both seats of the Super Cub.

The control of the flow of hot air for heating the cabin is obtained through the use of the cabin heat control in the left side panel control box. Cooling air is admitted through the sliding windows on the left side of the cabin. For special purpose flights, such as photography, hunting, etc., the right door and window can be opened in flight, but care should be taken not to impose high air loads on the window in the open position.

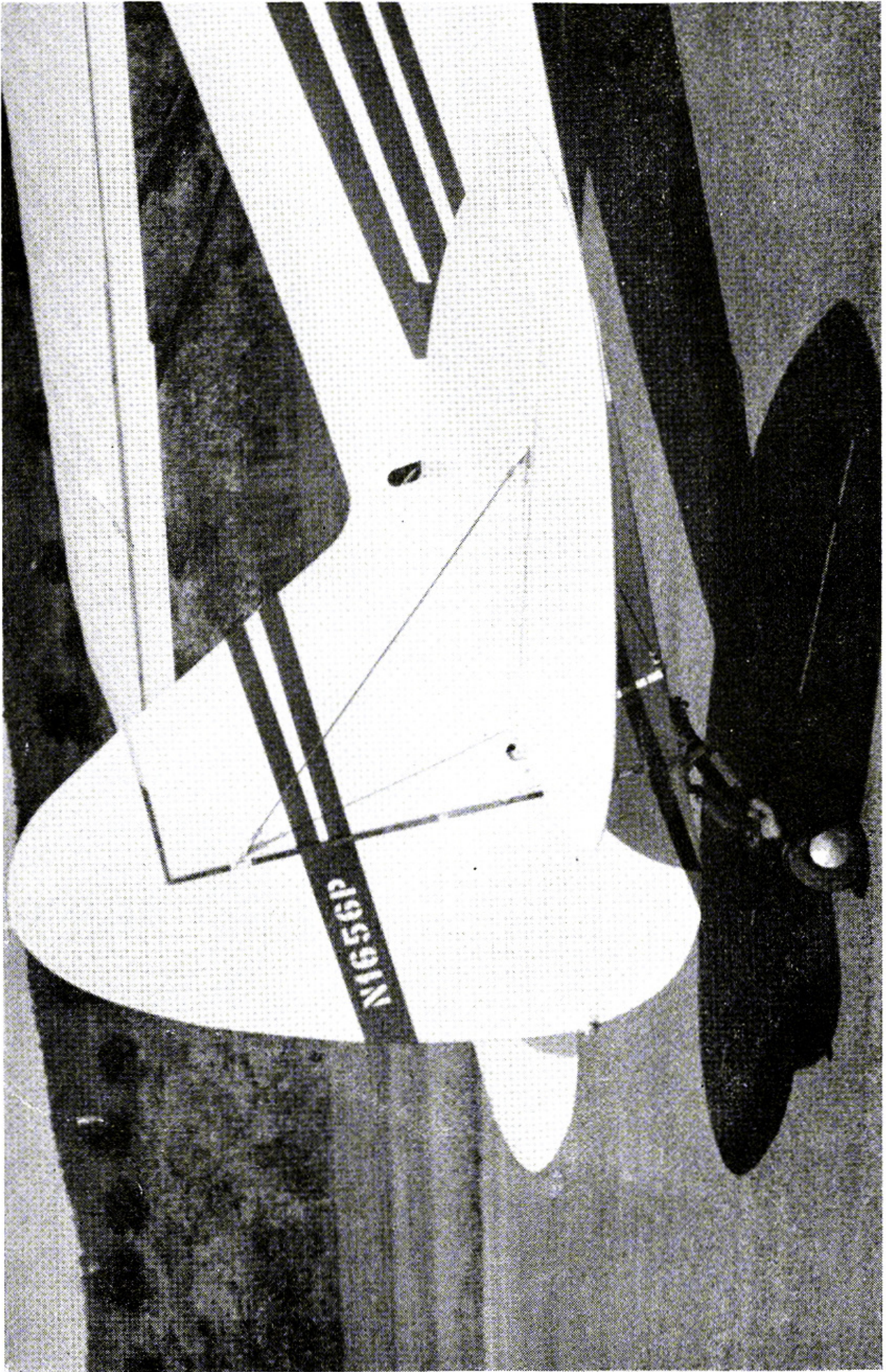

Figure 7

SECTION TWO

OPERATING INSTRUCTIONS

I. FLIGHT PROCEDURE:

1. STARTING:

When the engine is cold, prime three to five strokes after turning fuel valve to the proper tank. Push mixture control to full rich, carburetor heat off, and open throttle about one-eighth of an inch or until the intake of air at the carburetor can be heard when the engine is pulled through by hand. Engine should be pulled through at least four times.

Next turn the ignition switch to "both" and with brakes set, have engine pulled through by hand or engage starter if installed. If the engine does not start in the first few revolutions, open the throttle while the engine is turning over with ignition on. When engine starts, reduce throttle.

If the above procedure does not start the engine, reprime and repeat process. Continue to load cylinders by priming or unload by turning over the engine with the throttle open.

If engine still does not start, check for malfunctioning of ignition or carburetor system.

When the engine is warm, do not prime, but turn ignition switch to "both" before pulling propeller through. Engine should start after it has been rotated through four compression strokes. If turned over more than four times the engine will frequently "load up", after which it should be started with the throttle well advanced.

2. WARM UP AND GROUND CHECK:

As soon as the engine starts, the oil pressure should be checked. If no pressure is indicated within thirty seconds, stop the engine and determine the trouble.

Warm up the engine at 800 to 1000 R. P. M. for not more than two minutes in warm weather, four minutes in cold weather. The magnetos should be checked at 1800 R. P. M., the drop not to exceed 100 R. P. M. The engine is warm enough for take-off when the throttle can be opened without engine faltering.

Carburetor heat should be checked during the warm up to make sure the heat control operation is satisfactory and to

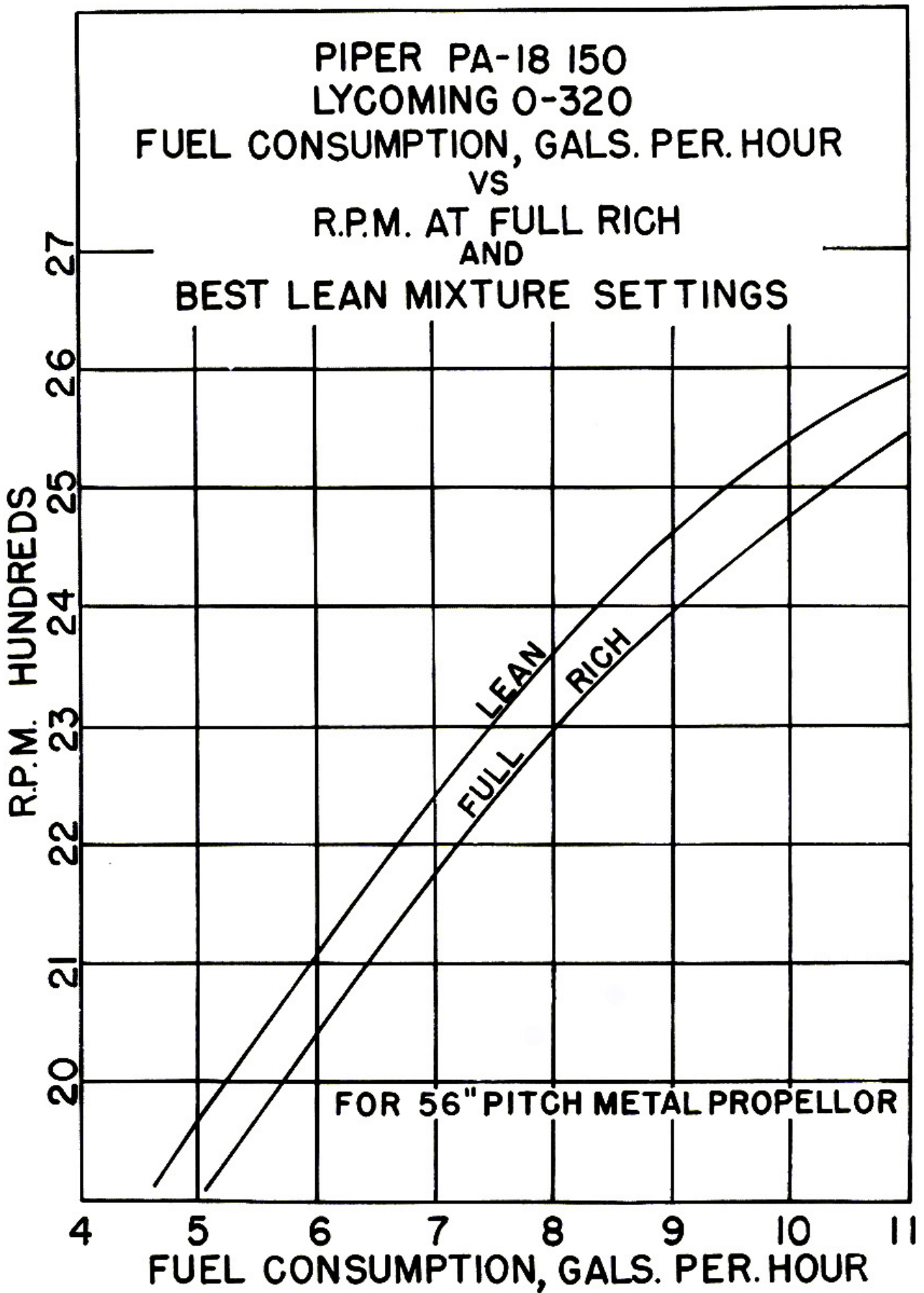

Figure 8

clear out the engine if any ice has formed. It should also be checked in flight occasionally when outside air temperatures are between 20° and 70° to see if icing is occurring in the carburetor. In most cases when the engine loses speed without apparent cause, the use of carburetor heat will correct the condition.

3. TAKE-OFF, CLIMB, AND STALLS:

The stabilizer adjustment should be set approximately in the neutral position for take-off. Fuel selector should be on the correct tank, carburetor heat off, mixture full rich. The flaps can be lowered if desired, but should be retracted as soon as climbing airspeed has been reached to achieve maximum rate of climb. The best rate of climb air speed at gross load is 75 M. P. H. on both models of the PA-18. At lighter weights, the best climbing airspeed will be reduced considerably.

The gross weight power off stalling speed with full flaps in the Super Cub "150" is 43 M. P. H.; with flaps up the stalling speed increases about 4 M. P. H.

4. CRUISING:

The cruising speed of the Super Cubs at 75% of rated engine power, at gross load under standard sea level conditions, is 100 M. P. H. for the Model PA-18 "95" and 115 M. P. H. for the model "150". Cruising airspeed and engine R. P. M. will depend on the propeller installed on the airplane.

Normally the "95" should be cruised at 2275 R. P. M. and the "150" at 2400 to 2450 R. P. M., but the 75% of power R. P. M. (low altitudes) can be determined as follows:

1. Fly the aircraft as near sea level as practicable at full throttle until maximum speed is reached. Note R. P. M. at top speed, level flight.
2. Reduce the maximum R. P. M. by 10% and cruise at 90% of full R. P. M. The correct cruising R. P. M. will result in a cruising airspeed of 100 M. P. H. with a fuel consumption of approximately 5 gallons per hour at full rich mixture on the "95", and an airspeed of 110 M. P. H. with a fuel consumption of approximately 9 gallons per hour on the "150". If the "150" is slowed down to the same cruising speed as the "95" or about 100 M. P. H., approximately the same amount of fuel, about 5 gallons per hour, will be used. (See fuel consumption chart, figure 8)

The metal propeller with which the PA-18 "135" is equipped as optional equipment is, unless specified otherwise, a 56 inch pitch propeller which favors take-off and climb rather than cruising speed. The use of this propeller reduces engine power output at normal cruising R. P. M. and therefore improves fuel economy considerably. At 2400 R. P. M. under standard conditions, the engine equipped with this propeller will be producing only about 60% of power rather than the 75% normally used. Fuel consumption will approximate 6.1 gallons per hour instead of the 7.7 gallons consumed at 75% of power.

For training and other purposes which do not require use of full power settings to obtain satisfactory performance, it is recommended that this propeller be operated, during take-off, climb, and cruise, at 2200 R. P. M. or less. This will still provide more performance than was formerly available in 65 H. P. trainers, and will reduce fuel consumption and engine wear very appreciably.

The fuel consumption chart, (figure 10) should be consulted to determine most economical cruising R. P. M. for specific requirements.

A considerable saving in fuel usage can be effected in either model by judicious use of the mixture control during cruising flight. The continuous use of carburetor heat during cruising flight increases fuel consumption. Unless icing conditions in the carburetor are severe, do not cruise with the carburetor heat on. Apply full carburetor heat only for a few seconds at intervals determined by icing severity.

5. APPROACH AND LANDING:

During the approach, trim the plane with the stabilizer adjustment until no force is required on the stick to maintain a gliding speed of 70 M. P. H. Lower the flaps at an airspeed not to exceed 85 M. P. H. The mixture should be full rich, fuel valve on correct tank. The carburetor heat need not be used unless icing conditions prevail, but the engine should be cleared occasionally by opening the throttle.

During the landing roll the steerable tail wheel should be used for directional control, and brakes used as little as possible to avoid excessive brake and tire wear.

To stop the engine after landing, pull the mixture control full out to idle-cut off. After the engine stops, turn the ignition and master switch (if any) off.

6. WEIGHT AND BALANCE:

For weight and balance data, see the weight and balance sheet which gives the exact weight of the airplane and permissible center of gravity conditions.

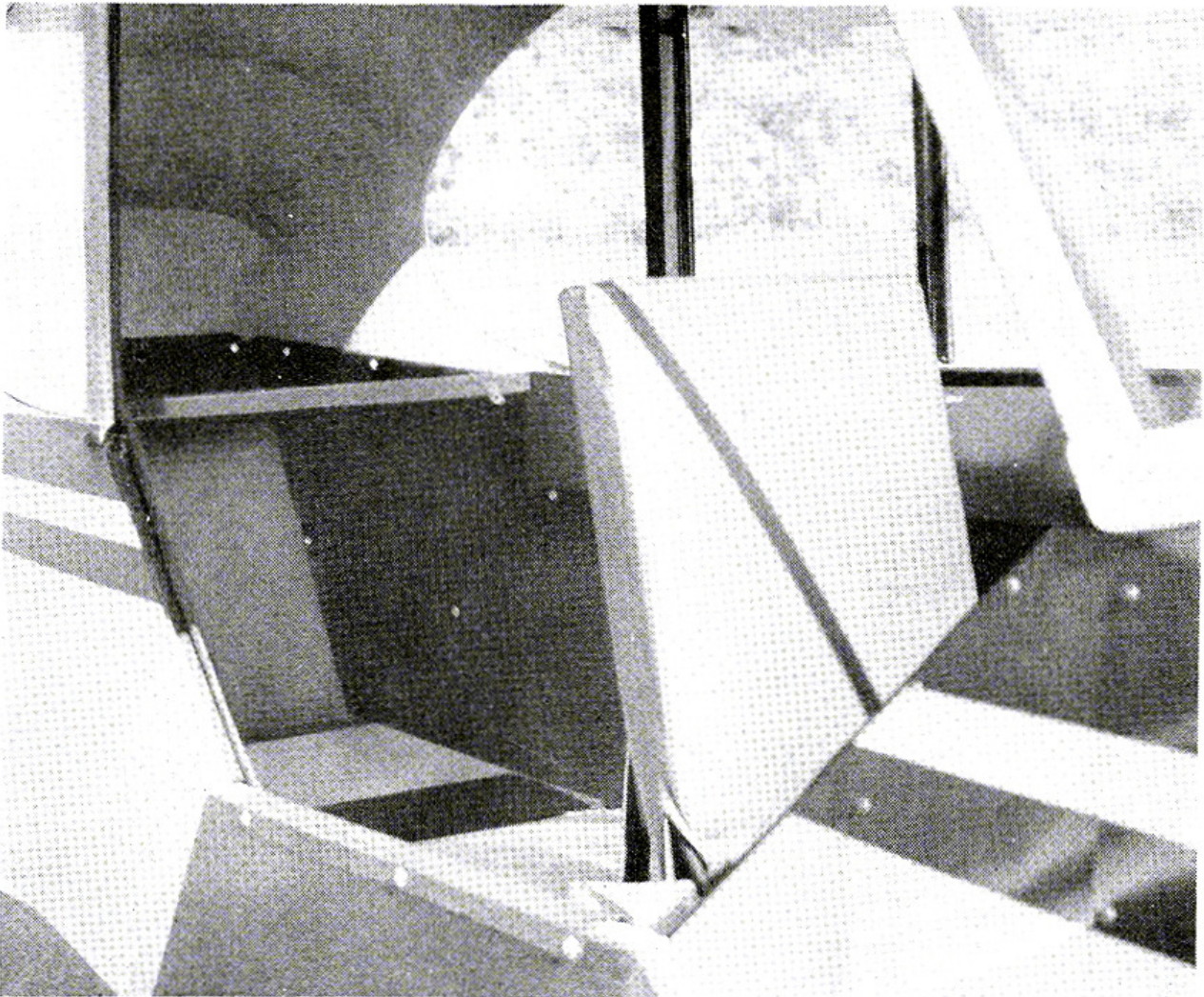

Figure 9

SECTION THREE

GENERAL MAINTENANCE

I. LEVELING AND RIGGING:

The Airplane Should Be Leveled As Follows:

Suspend a plumb bob on a string from the hole in the rear of the upper door frame channel. The hole is exposed by removing the wing root fairing at this point. The airplane will be leveled longitudinally and laterally when this plumb bob hangs directly over a depression in the horizontal door frame tube, about one inch ahead of its rearward end.

Lateral leveling: Place jacks or blocks under the inside portion of the axles, adjusting them until the plumb bob is roughly in line laterally with the mark on the door frame.

Longitudinal leveling: Support the tail on an adjustable jack or stand so that the airplane is approximately in level flight. Adjust the jack until the plumb bob is in line longitudinally with the reference mark.

Next readjust the lateral leveling jacks until the plumb bob hangs directly over the designated mark. The airplane is then leveled on both axes.

Rigging Of The Aircraft Is Done As Follows:

1. Dihedral angle: Place a block $\frac{3}{8}$ " high on one end of a 30" level. Hold the level between the jury strut and the main strut attachments under the front spar with spacer block outboard. When the bubble is centered, the front spars have an angle of 45 minutes off level.

Normally the correct dihedral will be obtained when about seven threads on the lift strut adjustment forks are exposed. (A maximum extension of 15 threads is permissible). If proper rigging does not result from this procedure, check the fuselage for lateral leveling by holding a level between the front landing gear bolt heads, using this means to level the fuselage laterally, rather than the plumb bob. Then recheck for equal and proper dihedral of the wings.

2. Wash out: Place a $\frac{3}{8}$ " spacer block on top of a 30 inch level at one end. Working on the outboard aileron rib, hold the level fore and aft with the spacer block at the rear and the front end of the level under the front spar. The correct wash out will exist when the bubble is centered. Adjust the rear struts in or out to obtain this condition.

3. Tail Assembly: With the airplane in level position, the stabilizer should be leveled at their rear spars by adjusting the tail brace wires. The elevator hinge line should be straight from tip to tip. The fin should be vertical at the rudder post.

II. TIRE INFLATION:

For maximum tire service, keep the tires inflated to the proper pressure, which is 18 pounds on the Super Cub. Reverse the tires on the wheels, if necessary, to produce even wear.

III. BATTERY SERVICE:

A Reading 12-volt 33 ampere hour battery is installed with the electrical equipment as optional equipment. The battery should be checked frequently for proper fluid level. *Do not fill the battery above the baffle plates.* Be sure all connections are clean and tight. If battery is not up to proper charge, recharge, starting with a charging rate of four amps and finishing with two amps. If a quick charge is desired for the battery, be sure master switch is off while charging.

IV. BRAKE SERVICE:

The brake system is filled with Univis #40 (petroleum base) hydraulic brake fluid. This should be checked at every 100 hour inspection, and replenished if necessary.

Do not use or mix mineral or vegetable base brake fluids when refilling system. When it is necessary to refill brake system, or when the brakes seem spongy, probably due to air in the lines, the following procedures are to be followed:

1. To fill the brake system, remove filler plugs on right wheel brake master cylinder. Remove bleeder screw from tee on right wheel brake unit and attach line from brake fluid pressure can. Fill system until master cylinders are full. Repeat procedure for left wheel brake. If pressure can is not available, an open can with line attached may be used, providing can is held higher than master cylinders. When all master cylinders are full, replace filler plugs and bleeder screws. Check brakes for satisfactory operation.

2. Air in the brake lines causes faulty operation which can be corrected by bleeding the brake system as follows:

- a. Check entire system for breaks or leaks.

b. Remove bleeder screw from particular brake unit and insert bleeder hose. Place free end in a clean receptacle.

c. Remove filler plug from master cylinders of the particular brake which is being bled.

d. Fill master cylinders with Univis #40 hydraulic fluid and keep cylinders full during bleeding process.

e. Work the brake pedal rapidly to force fluid through bleeder hose into receptacle. Pinch hose shut during return of pedal to off position. Release pressure on hose, and push pedal on rapidly again. While fluid is flowing, restrict bleeder hose and allow brake pedal to return slowly to off position. Continue this process until no more air bubbles are observed coming through bleeder hose. The system is then properly bled.

f. Replace bleeder screw; check to see that master cylinders are full, and replace filler plugs. Check brakes for satisfactory operation.

No adjustment of the brake clearances is necessary on the Super Cub brakes. If, after extended service, the brakes become less effective, the brake segments can be easily replaced as follows: Remove the wheels to expose the brake shoe blocks, then slip blocks from their retainer clips with a screwdriver. Replace with new brake segments and reinstall the wheels.

Wheels are quickly removed by taking off the hub caps, removing the cotter pin from the hub nut and unscrewing the nut. The wheel can then be pulled freely from the axle.

Tires are dismounted from the wheels as follows:

1. Deflate tube.
2. Remove safety clevis pin from outer wheel flange.
3. Extract lock ring which holds the outer flange in place.
4. Slide flange, tire and tube from the hub.

V. FUEL REQUIREMENTS:

Aviation Grade 80-87 octane gasoline should be used in the Super Cub. The fuel gauge glass should be cleaned occasionally so that the fuel level indicator will always be readily seen. To clean or replace the fuel gauges, first remove lower wing butt fairings. Pinch the rubber line to the lower gauge fitting so that fuel cannot drain from the tank. Then remove the fuel gauges by pulling the fittings from the connecting rubber tubes.

The oil capacity of the 0-320 engine on the "150" is 8 quarts. It is recommended that the engine oil be changed every 50 flying hours, or sooner under certain conditions. The minimum safe quantity of oil required is 2 quarts. The following grades are recommended for the specified temperatures:

Temp. above 40°F	SAE 50
Temp. below 40°F	SAE 30

The oil capacity of the C-90-8F, or 12F engine on the "95" is 5 quarts, and the grades to be used at various temperatures are the same as those for the 0-320 engine.

VI. CARE OF WINDSHIELD AND WINDOWS:

The windshield and windows are made of plexiglas and a certain amount of care is required to keep them clean and clear. The following procedure is suggested:

1. Flush with clean water and dislodge excess dirt, mud, etc. with your hand.
2. Wash with mild soap and warm water. Use a soft cloth or sponge. (Do not rub).
3. Remove oil, grease or sealing compounds with a cloth soaked in kerosene.

NOTE: Do not use gasoline, alcohol, benzene, carbon tetrachloride, lacquer thinner, or window cleaning sprays.

4. After cleaning, apply a thin coat of hard polishing wax. Rub lightly with soft dry cloth.
5. A severe scratch or mar can be removed by using jewelers rouge to rub out scratch, smooth on both sides and apply wax.

VII. LANDING GEAR SERVICE:

The landing gear shock cords, which are enclosed in streamlined shock cord covers, should be inspected regularly for signs of wear. Shock struts and landing gear hinge bolts should be kept properly lubricated with light grease or oil.

SECTION FOUR

INSPECTIONS

ENGINE SECTION

ITEM 1—OPERATION:

- Run engine to minimum 120° oil temperature—check full throttle static R. P. M. both magnetos.
- Check magnetos 100 R. P. M. drop at 1800.
- Check carburetor heat 100 R. P. M. drop at F/T.
- Check ignition switch for operation.
- Check idle R. P. M. 550-600 carburetor heat off.
- Oil Pressure (PA-18 "95"—Minimum idle 10# Normal 30-35#).
(PA-18 "150"—Minimum idle 25# Normal 65-85#).
- Master switch on, check generator and voltage regulator for operation.
- Battery fully charged will show very slight indication on Ammeter at F/T.
- Check idle cut-off at 800 R. P. M.; engine should cut off clean.

Continental C90-8F or C90-12F	Rated R. P. M. 2475
Static R. P. M. Wood Fixed Pitch	2100-2400
Static R. P. M. Metal Fixed Pitch	2200-2350

Lycoming O-320	Rated R.P.M. 2700
Static R. P. M. Metal Fixed Pitch	2350-2450

ITEM 2—ENGINE MOUNT:

- Check engine mount for damage and cracks at gussets or in corners.
- Inspect protective finish on mount; sand and touch up bare areas.
- Inspect rubber shock mounts for rubber deterioration and tension.
- Engine mount bolts should be tightened to 60 to 80 inch pounds.
- Check mount bolts for safety.

ITEM 3—COWLING:

- Clean and inspect engine cowling for dents and cracks at hinges and reinforcement.
- Check for tension adjustment on cowl doors at latch.
- Tension prevents vibration and cowl cracking.
- Check baffles for cracks and leather installation to prevent chafing.

ITEM 4—MAGNETOS:

- Check magnetos for secure attachment.
- Check breaker point housing for excessive oil.
- Check points for gap and pitting. Gap setting .012".
- Check plug wiring connections at magneto and wire insulation for deterioration and chafing.
- Check grommets at baffles.

ITEM 5—OIL DRAIN:

- Drain oil and check for metal particles.

Remove, clean and check oil screen drain plug and inlet oil temperature housing for metal particles.
Reinstall and safety oil drain plug.
Check oil cover for leaks and flexible lines for deterioration.

ITEM 6—SPARK PLUG:

Remove plugs, bomb blast and clean.
Plugs with badly burned electrodes should be replaced.
Reset gap to .025".
Reinstall using thread lubricant to prevent seizing and torque to 300 to 360 inch pounds or 30 foot pounds.

ITEM 7—STARTER:

Check starter motor for mounting security.
Check commutator for excessive wear and bridging.
Inspect wiring insulation for deterioration and connections.
Check ring gear for damaged teeth and nose cowl clearance.
Check starter shaft bushings for play.
Check brush retention and tension springs.

ITEM 8—GENERATOR:

Check generator mounting for security.
Check brush retention and condition of tension springs.
Replace worn brushes before there is any danger of brush failure.
Brush worn over 3/16 of an inch should be replaced.
Check generator drive belt for 3/4" hand deflection.

ITEM 9—CARBURETOR AND HEATER:

Check carburetor for mounting security.
Inspect carburetor bowl for cracks, particularly at inlet.
Drain carburetor float chamber and check inlet finger screen-resafety.
Operate throttle in cockpit to be sure that throttle arm hits stops in open and closed positions without binding or sticking.
Check operation of mixture control for binding or sticking and full rich position.
Inspect carburetor air box for security and cracks—heater valve for full travel.
Check rubber intake hose connections for deterioration and clamp security.
Check intake system for leaks and cracks.
Clean air filter in kerosene and saturate with #10 oil and allow to drain before installation.

ITEM 10—FUEL LINES:

Check fuel lines for leaks and hose deterioration.
Check hose supports for security and chafing.
Drain and clean fuel strainer and resafety.
Check for stains around fuel system indicating leaks.
Check all connections for tightness.

ITEM 11—EXHAUST STACKS:

Check stack flanges for security, cracks and leaks.

Remove all heater and muffler shrouds and inspect for corrosion, cracks and leaks that might transfer gas to the cockpit, particularly through the cabin heater system.

Check tailpipe, muffler and stacks for security at all clamps and slip joints. Check cabin heater box and control valve for operation.

Check cabin and carburetor heat flexible tubing for security and general condition.

ITEM 12—FIREWALL:

Check firewall for open holes and gas leaks from engine compartment.

Check all controls for grommets and sealing putty.

PROPELLER SECTION

ITEM 13—ALIGNMENT:

Remove spinner and check for cracks or dents in spinner and back plate.

Check wood propeller for separated laminations, cracks, loose metal tipping and protective finish. Blades are to track within 1/16".

Wood propeller hub bolts are to torque from 140 to 150 inch pounds.

Metal propeller hub bolts are to torque from 250 to 275 inch pounds.

COCKPIT, PASSENGER AND CARGO SECTION

ITEM 15—SEATS:

Check rear seat cushions and attachments for wear or deterioration.

Check front seat fore and aft adjustment and lubricate track.

Check condition of safety belts and operation of buckles.

ITEM 16—WINDSHIELD:

Check weatherstripping for security in channels and for weather leaks.

Visual check for cracks, crazing, distortion and discoloration.

ITEM 17—POWER INSTRUMENTS:

Check power plant instruments for mounting security.

Check connections and plugs.

Check placards and limitation markings.

Continental C-90 Series Engine:

Tach:

Red Line ----- 2475 R. P. M.

Yellow Arc ----- 2350—2475 R. P. M.

Green Arc ----- 2000—2350 R. P. M.

Oil Pressure:

Red Line ----- Minimum 10 lbs. Maximum 40 lbs.

Yellow Arc ----- 10 lbs.—30 lbs.

Green Arc ----- 30 lbs.—40 lbs.

Oil Temperature:

Red Line -----	225°
Yellow Arc -----	40°—90°
Green Arc -----	90°—225°

Lycoming O-320 Series Engine:

Tach:

Red Line -----	2700 R. P. M.
Green Arc -----	500—2700 R. P. M.

Lycoming O-320 Series Engine:

Oil Pressure:

Red Line -----	Minimum 25 lbs.	Maximum 100 lbs.
Yellow Arc -----	(25 lbs.—65 lbs.)	(85 lbs.—100 lbs.)
Green Arc -----		(65 lbs.—85 lbs.)

Oil Temperature:

Red Line -----	245°
Yellow Arc -----	40°—120°
Green Arc -----	120°—245°

ITEM 18—FLIGHT INSTRUMENTS:

Check flight instruments for mounting security.

Check connections and plugs.

Check placards and limitation markings.

<i>Air Speed:</i>	<i>PA-18 "95"</i>	<i>PA-18 "150"</i>
Red Line	138 M. P. H.	153 M. P. H.
Yellow Arc	110—138 M. P. H.	121—153 M. P. H.
Green Arc	49—110 M. P. H.	47—121 M. P. H.
White Arc (Flap operation)		43—85 M. P. H.

ITEM 19—SWITCHES—LIGHTS—FUSES:

Check battery cable connections for security.

Check circuit breaker wire connector for security and insulating sleeves.

Check position and landing light switches for placards and operation.

A circuit breaker is used on all circuits except the Stall Warning Indicator.

ITEM 20—INTERIOR TRIM:

Check cockpit post fairings and all metal trim for security.

ITEM 21—DOOR LATCH AND HINGES:

Check door hinge and rivets for looseness.

Check door latch plunger for complete extension to prevent doors opening while taxiing.

Check door for improper fit or damage resulting in air leaks.

ITEM 22—ENGINE CONTROLS:

Check mixture control for panel placard and operation for smoothness.

Check carburetor heat for panel placard and smoothness of operation.

Check throttle for smooth operation.
Check primer for operation and leaks behind the panel.
Check cabin heat for panel placard and full travel of heater butterfly valve.
Check ignition switch for panel and terminal security.
Check for placard—Off, Left, Right and Both.

ITEM 23—CONTROLS:

Check aileron and elevator control torque tube for excessive play.
Check pulleys and cable attachments.
Check aileron arm attachment on torque tube.
Check control stick bolts.

ITEM 24—RUDDER PEDALS AND LINKAGE:

Check rudder pedal assembly for play and travel freedom.
Lubricate hinges and torque tube bearings and check for safety.
Check rudder pedal return springs for attachment.

ITEM 25—FLAP CONTROLS:

Check flap handle for placard and condition of ratchet for flap positions.
Check flap torque tube for excessive play.
Check flap cable attachments.
Remove rear baggage compartment cover and check flap pulleys at the top and bottom of fuselage.
Remove rear wing butt fairings and check cable fairleads.
Through wing inspection openings check the attachment of flap return springs.

ITEM 26—CABLES AND PULLEYS:

Check all cables for broken strands.
Check reversing and idler pulleys on elevator control.
Check aileron pulleys outboard from control arm.

ITEM 27—FLIGHT CONTROL OPERATION:

Check aileron, rudder and elevator controls from cockpit for smooth operation.
Check stick for neutral position with control surfaces streamlined.

ITEM 28—TRIM CONTROLS:

Check stabilizer trim control for smooth operation.
Check indicator against stabilizer for proper position.

ITEM 29—FUEL VALVES:

Check fuel valve for smooth operation.
Check placard for "ON" and "OFF" positions.
Check valve for leaks.

LANDING GEAR

ITEM 30—SHOCK STRUTS:

Check shock cords for deterioration.

ITEM 31—WHEELS AND AXLES:

Remove wheels, wash, check and relubricate bearings.
Check brake shoes for wear and drums for scoring.
Check brake expander tube for leaks.
Install wheel and axle nut only tight enough to remove end play.

ITEM 32—TIRES AND FAIRINGS:

Check tires for 18 pounds of air pressure.
Replace tires that have cord showing.

ITEM 33—BRAKES:

Check brake reservoirs for fluid and assembly for leaks.
Check operation and holding ability of brake and parking brake.

ITEM 34—LANDING GEAR VEES:

Hoist aircraft and check gear bushings; vee bushings are replaceable if worn.
Check for skin wrinkles indicative of inside damage.

ITEM 35—TAIL WHEEL:

Check tail wheel and spring assembly for looseness.
Check condition of tail spring pad.
Remove wheel, wash and repack bearing.

FUSELAGE

ITEM 36—FABRIC:

Check condition of fabric with the eraser end of a pencil, particularly on top surfaces.
Check the finish for cracks or checks. Sand out and repaint all checks or cracks to preserve the fabric.

ITEM 37—WING FITTINGS:

With wing root fairings removed, inspect wing fittings with a flashlight and magnifying glass for minute cracks in the ears. Check bolts to be sure that there are no threads in bearing and that bolts are properly safetied.
Check wing fitting holes for elongation by having some one pull up and down on the wing tips.

ITEM 38—LANDING GEAR FITTINGS:

Inspect all fittings with flashlight and magnifying glass for signs of cracks or hole elongation.

ITEM 39—FUSELAGE STRUCTURE:

Through inspection openings and through the baggage compartment rear plate check the condition of all tubing for rust, damage and protective coating.
Check all wood stringers for damage and security.

ITEM 40—DEBRIS—IN FUSELAGE:

Check the bottom of the fuselage and fabric under floor boards for bolts, nuts and other objects that might jam controls or pulleys.
Check the rear of fuselage for open drain grommet.
If considerable dirt or oil exist on the fuselage bottom, use a non-caustic soap and wash out the dirt to prevent fabric rot.

ITEM 41—CONTROL CABLES:

Check for broken control cable strands by sliding a cloth over the cable in vicinity of Fairleads.
Check upper and lower elevator turnbuckles for safety and maximum of three threads showing outside of barrel.
Check bungee spring attachment at upper elevator horn and pulley at stabilizer yoke for wear and safety.
Check rudder cable fairleads and cables for wear aft of baggage compartment.

ITEM 42—FAIRINGS:

Check tail assembly fairings for cracks and missing metal screws.

WING, AILERONS AND FLAPS

ITEM 43—WING FABRIC:

Check left and right wing fabric for holes, cracks or checks in the finish and open drain grommets at each rib bay trailing edge. (Fabric usually deteriorates first on the upper surface of the wing or along the trailing edge).
Install inspection grommets at drag wire fittings to inspect drag wires for tension and wing ribs and compression members for damage.

ITEM 44—STRUTS:

Check right and left wing strut fittings for elongation by lifting up and down on the wing.
Check bolts for fitting attachment to the spar.
Check struts for dents or cracks. Sight down strut trailing edge to ascertain that struts are straight.
Check strut end forks and fork lock nut. The maximum number of threads allowed outside of the strut end is fifteen.

ITEM 45—BOLTS:

Check strut attachment bolts to be sure that there are no threads in bearing and bolts are properly safetied.

ITEM 46—AILERONS:

Check both ailerons for wrinkles which are possible signs of structural damage.
Check each rib bay for an open drain grommet.
Check condition of fabric and finish, refinishing any dope cracks, checks, or ringworm.

ITEM 47—AILERON HINGES:

Check aileron hinge legs for security at rear spar and false spar.
Check hinge pins for wear and safety. Worn or loose pins must be replaced.

ITEM 48—AILERON CONTROL:

Remove inspection covers and check the cables in each wing for interference and chafing.
Check the pulleys in each wing for condition, wear and safety and lubricate pulley bearings.
Check wear and safety of the fairleads in each wing.
Aileron travel— 18° up 18° down $\pm 2^\circ$.
Stop at aileron should engage first to allow for full travel of ailerons.
Check the four aileron horn bolts for wear, threads in bearing and safety.
Check the turnbuckle in left wing to see that it is safetied and not more than three threads are showing outside the barrel.
To locate broken strands at fairleads or pulleys slide a cloth over the cable, all cables with broken strands to be replaced.

ITEM 49—FLAP COVERING:

Check fabric condition of both flaps with a pencil eraser end for deterioration.
Check condition of finish for cracks, checks, or ringworm and refinish any that exist.
Any internal structural damage will cause wrinkles on the fabric surface.

ITEM 50—FLAP ATTACHMENTS:

Each flap has two hinges and two hinge legs that are riveted to the wing false spar and attached with a single bolt to the wing rear spar. Lowering the flaps at over 80 M. P. H. can cause possible damage to these hinge legs so a careful inspection is recommended.
Check stop in up position for streamline of flap.
Check the hinge pins for wear and installation of washers and safety.

ITEM 51—MECHANISM—FLAP:

Check fafnir rod end bearings and push pull tube for clearance through hole drilled in the fafnir bearing rod to check minimum distance the push pull tube is screwed in the fafnir rod. Be sure lock nut is tight.
Ascertain through inspection that both flap return springs are secure and in good condition. Operate flaps and check springs to be sure they do not chafe, bind or interfere with other controls or adjacent structure.
Check travel: Full Flap $50^\circ \pm 2^\circ$.
Check bellcrank casting for cracks, particularly at the ears and for safety and security of the bracket.

ITEM 52—WING ROOT FAIRINGS:

Check left and right top wing root fairings for tension, adjustable through a hole at the trailing edge.
Check all metal screws for security and the fairing for cracks.

EMPENNAGE

ITEM 53—FABRIC—STABILIZER:

Check stabilizer fabric condition and drain grommets for restrictions.

Check stabilizer rear hanger tube and front link tube for hinging action.

Small holes are drilled in the fuselage tube and stabilizer link tube to drop oil in for lubrication. Lubrication of these tubes is very important and often neglected, resulting in freezing up of the tubes.

Lift up and down on the stabilizer checking for excessive play in the stabilizer yoke screw. The nut on the bottom of the screw pulley will take up play if excessive.

Check stabilizer yoke casting for cracks and link tube ears for worn bolts and safety.

ITEM 54—FABRIC—FIN:

Inspect vertical fin for fabric condition and finish.

Check for wrinkles, dents and signs of internal damage.

ITEM 55—FABRIC—RUDDER:

Inspect fabric cover on the rudder for fabric and dope condition.

Check bottom of rudder for an open drain grommet.

Check rudder for alignment and possible internal damage usually indicated by a wrinkle in the fabric.

Inspect rudder hinge pins for wear and safety.

Check hinge bushings for play; these bushings are pressed in and should be replaced when worn.

Check rudder stops to ascertain full travel:

20° Right and 20° Left $\pm 2^\circ$.

ITEM 56—ELEVATORS:

Check fabric condition and finish on the elevators.

Check for open drain grommets along the elevator trailing edge.

Sight one elevator against the other for alignment.

Check hinge pins and bushings for wear and replace any worn pins or bushings.

Check elevator cable horns for safety, worn bolts and clearance in travel.

Check elevator stops to ascertain full travel:

25° up—15° down $\pm 2^\circ$.

ITEM 57—TAIL BRACE WIRES:

Check empennage rigging wires for corrosion and cracks or nicks that might result in failure.

Check fittings for alignment with the wire and bolts for safety.

Rigging wires should be taut with little hand deflection.

Check each wire to be sure there are no loose fork lock nuts.

ITEM 58—EMPENNAGE CONTROLS:

- Check rudder and elevator horns for worn bolts and safety with no threads in bearing.
- Check horns for alignment with the cable and freedom of travel.
- Check top and bottom cable turnbuckles for safety and a maximum of three threads showing outside of the barrel.
- Sight the cables through the fuselage for interference and chafing.

ITEM 59—ELECTRICAL SYSTEM:

- Check wiring for chafing, clamping.
- All terminals tight.
- Bonding straps secure.
- Landing lights—mounting and operation.
- Battery installation—terminals secure. Charged, no acid spillage.
- Radio installation for security and operation.
- Safe Flight Indicator for operation.
- Circuit breakers or fuses for security.

ITEM 60—FLOATS:

- Sight check rigging.
- All brace wires tight and safetied.
- Water ballast, if carried.
- No leaks in floats. Check structure.

ITEM 61—

- All C. A. A. Mandatory Bulletins complied with.

SECTION FIVE

WARRANTY

Piper Aircraft Corporation hereby warrants each new airplane and part manufactured by it to be free from defects in material and workmanship under normal use and service, its obligation under this warranty being limited to making good at its factory any part or parts thereof which shall, within ninety (90) days after delivery of such airplane or part to the original purchaser or fifty (50) hours of operation, whichever shall first occur, be returned to it with transportation charges prepaid and which its examination shall disclose to its satisfaction to have been defective. No other warranty shall be implied by law or otherwise, and no other or further obligation or liability shall be incurred by Piper Aircraft Corporation by reason of the sale of any airplane or part thereof or its use whether for breach of warranty (expressed or implied by law, or otherwise) or negligence in manufacture, or otherwise. Upon the expiration of the period above stated, any such obligation or liability shall terminate. In no event shall Piper Aircraft Corporation be liable for special or consequential damages. No distributor, dealer, agent, or employee of Piper Aircraft Corporation is authorized to extend any other or further warranty, or incur any additional obligation, in its behalf in connection with the sale of its products.

This warranty shall not apply to any airplane or part manufactured by Piper Aircraft Corporation which shall have been repaired or altered outside of its factory, or which has been subject to misuse, negligence or accident.

Piper Aircraft Corporation makes no warranty whatever with respect to engines, wheels, propellers, ignition apparatus, starting devices, generators, batteries, instruments or other trade accessories, inasmuch as they are usually warranted separately by their respective manufacturers.

PIPER AIRCRAFT CORPORATION.

VOLUME TWO

**Model PA-18A
Agricultural Version of the
Piper Super Cub**

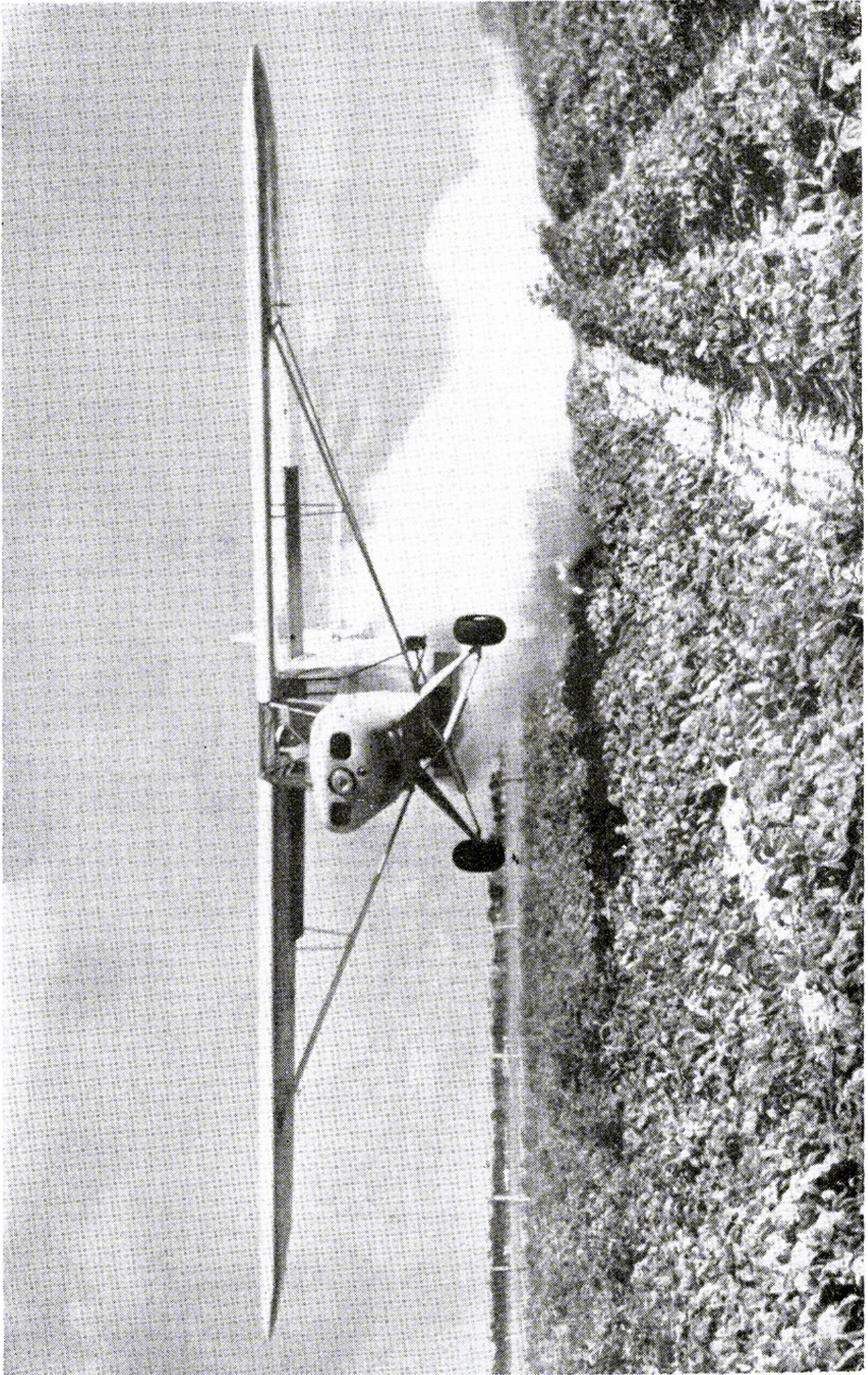

Figure 10
40

SECTION I

General Design

The PA-18A is basically a version of the well known and well proven Super Cub, which has been very considerably modified to make provision for the latest developments in agricultural dispersal equipment. In order to make possible the convenient installation and removal of a high capacity tank, the fuselage structure in the rear seat and baggage compartment area has been altered, with some tubular members removed to make room for the tank and replaced by structural sheet metal pieces. Other tubes have been added to provide attachment points for the tank or related accessories.

Other than the changes to the fuselage in the vicinity of and aft of the rear seat, there have been no major modifications to the PA-18 in the PA-18A. The wings, landing gear, engine installation and tail surfaces are all identical. The fuel system is essentially the same, and the electrical system is changed only to the extent of moving the battery forward nearer the center of gravity of the plane to a location just behind the rear seat or tank, whichever is installed. The control system is changed by rerouting the flap cable, installing a modified torque tube in the single seat version, and replacing the standard elevator push-pull tube (inside the torque tube) and connecting upper elevator cable with one longer cable.

The PA-18A is available as a two-place plane with dual controls installed, in a cargo version with the rear seat area cleared for cargo hauling, or with the agricultural tank installed, with attachments for spraying, dusting, or both.

As a two-place airplane, the PA-18A is approved under Part 03 of the Civil Air Regulations with a standard license and at a gross weight of 1750 lbs. As an agricultural plane, it is licensed under Part 8 of the CAR and can be flown at a gross weight of 2070 lbs.

Other modifications incorporated in the PA-18A are:

(1) The fabric on the fuselage belly from the tank aft has been replaced with quickly removable aluminum panels, which facilitate cleaning of the interior of the fuselage and general maintenance on the fuselage.

(2) Wire cutters have been applied to the leading edge of the landing gear vees on sprayers or duster.

(3) A shoulder harness and a heavy duty safety belt are installed as standard equipment on the front seat.

SECTION II

Description of the Dispersal Unit

An 18 cubic foot aluminum tank is the principal part of both the spray and the dust units. This tank has a liquid capacity of 110 gallons, and a capacity of 500 to 1000 pounds of solids, depending on the specific gravity of the material used.

The tank is anchored to the fuselage structure at many points. At the top, the tank is bolted directly to the structure and to the top deck panel, which is in turn bolted to the fuselage members with 25 machine screws. Through the center of the tank runs a structural tube, the end plates of which are connected with a through-bolt to lugs on the upper longerons. Restraining straps tied to the structure with steel tie rods are located as follows: One on the forward face of the tank above the pilot's seat back; one ahead of the tank near the floor, and one aft of the tank at the same level. The bottom portion of the tank extends through the structure in the belly of the fuselage and is restrained at that point.

The bottom panels of the tank are formed of aluminum channels in an H section. To these are clamped with quick attaching clamps, either the bottom plates for the spray unit or for the dusting venturi. When the sprayer is installed, the clamps on the right tank outlet are quickly removable in flight through use of the dump valve control under the instrument panel. This allows the right sprayer plate to drop down, emptying the tank of liquid in 7 seconds.

The tank is constructed of heavy gauge aluminum, and is fitted with interior baffles to reinforce the tank and prevent surging of the liquid. The lateral baffles can be removed easily by pulling the wires from their attachment hinges, if desired for dusting work.

On the left side of the fuselage are welded lugs for attaching the duster gear box mount. This mount is bolted on with three bolts and to it is fastened the gear box and the brake unit for the agitator fan. The sprayer pump is mounted under the firewall on a second tubular mount.

Ahead of the lower part of the tank mounted on the floor is the control lever stand, with its control lever extending forward along the left side of the pilot's seat. The same lever is used to control output from either the spray or dust unit. To the center of the control lever is clamped the brake control, connected by a flexible wire cable to the brake assembly at the fan.

SECTION III

Operation of the Spray Unit

The spray unit has a liquid capacity of 110 gallons, a maximum output of about 90 gallons per minute, and a pressure range of from 20 to 90 pounds depending on nozzle orifice size and pressure regulator setting. The booms are fitted with 24 or 46 highest quality trouble-free Spraying Systems diaphragm type nozzles which give instant, positive shut-off. 24 nozzles are installed on the low volume sprayer booms, and 46 nozzles in the high volume booms.

All booms are aluminum Heli-arc welded units with end openings for cleaning. The booms are removed or installed with 4 bolts and 1 hose clamp, and are hinged in such a way as to fold back about 80 degrees when encountering an obstacle, reducing impact loads on the boom and the airplane.

A very effective system of pressure relief is employed to prevent a surge of pressure through the system when flow to the booms is shut off; with nearly constant pressure at the pump whether the flow is off or on, an even R. P. M. and pump output is maintained which provides more consistent unit output throughout spray runs. The pressure relief system consists of a dual shut-off arrangement in which a smaller shut-off valve, located in a by-pass line around the boom shut-off, opens when the main shut-off is closed, and vice versa. The liquid when not flowing to the booms (or to the pressure regulating valve on a second by-pass line) flows through the smaller shut-off, maintaining a maximum of 55 lbs. pressure and providing excellent agitation of liquid in the tank as it spurts through the right hand bottom plate.

Pressure in the system, as indicated on the pressure gauge in the instrument panel, is regulated by means of a regulating valve located on the lower face of the tank to the left of the pilot's seat. For maximum pressure the valve is closed, causing all fluid to flow to the booms when the main shut-off valve is opened. For minimum pressure, the valve is opened completely, permitting some of the fluid to by-pass back into the tank and reducing pressure in the booms. Ordinarily the regulating valve will be set at an intermediate position, determined by the pressure desired, and the by-passed liquid will create agitation as it flows into the left side of the tank when the unit is spraying. Thus agitation is provided whether the booms are on or off, as long as the pump is operating.

A fluid quantity gauge is mounted on the right side of the cockpit ahead of the door, calibrated for both level flight and three point attitudes. The glass tube in this sight gauge should be removed occasionally for cleaning.

The two bottom plates clamped to the bottom channels of the tank provide mounting for the dual liquid shut-offs, and outlets for the liquid as it flows to the pump. Mounted on the top of these plates inside the tank are two large strainers which serve to keep dirt out of the spraying system. The strainers are removed by snapping them off retainer clips, either by reaching down inside the tank or by lowering the bottom plates to make the strainers accessible.

Neoprene rubber molded gaskets are clamped between the bottom tank channels and the bottom plates to provide a liquid tight seal. The 24 nozzles on the low-volume sprayer are equipped with D-8 orifice and No. 45 cores. Two each extra orifices and cores of this size are supplied, along with 26 D-4 orifices. With this combination of orifices and cores, most of the desired lower output quantities can be applied.

The 46 nozzles on the high-volume unit are also fitted with D-8-45 orifices and cores. Two extra D-8 orifices and No. 45 cores are provided with this combination, as well as 48 D-12 orifices, 48 D-4 orifices, and 48 No. 56 cores. Tee fittings and pipe plugs for conversion to the 15 gallon per acre highest density application are included in this kit.

With the high-volume arrangement, quantities ranging from 23 gallons per minute and 3 gallons per acre to 90 gallons per minute or 15 gallons per acre can be applied. If other quantities than listed in the Spray Output Tables are desired, different orifices and cores or different nozzle spacing should be used.

Output quantities should be computed from the Tables (Figures 14 and 15) rather than from the Spraying Systems Chart because results obtained in actual spraying tests varied from the computed quantities on the chart. (The Spraying Systems Chart uses pressures at the nozzle orifice rather than pressures throughout the system).

The output of the spray unit per acre varies with several factors: (1) Pressure; (2) Size of orifices and cores; (3) Speed of plane; (4) Width of swath used. For purposes of standardization, a normal pressure of 40 pounds, a speed of 80 mph, and a swath width of 50 feet are recommended for average use. Any of these variables can be changed to give more satisfactory results under special circumstances.

The speed of the plane can advantageously be increased to 90 mph for use in large acreages, or slowed to 60 to 70 mph on small plots or for heavier application. At a given pressure, the rate of

application per acre will increase as the speed is reduced. A simple formula for determining the output per acre is:

$$\frac{\text{Swath width (feet) x speed (mph)}}{500} = \text{acres per min. covered.}$$

$$\text{Example: } \frac{50 \text{ ft. swath x 100 mph speed}}{500} = 10 \text{ acres min. covered}$$

For calibration purposes, the best way to determine the output of the spray unit is to put a small quantity of liquid in the tank, spray the liquid out in flight leaving an unusable quantity in the tank. Then put in 20 gallons and spray out this quantity, measuring the time required to put out 20 gallons, and converting to one minute of operation. Next apply the formula given above, dividing the output in one minute by acres covered per minute to get application per acre.

Example: If 20 gallons are sprayed out in one minute, divide 20 by 10 acres per min. (as covered in above example) to get 2 gal. per acre application.

The swath width covered by the spray unit under normal conditions is actually from 55 to 60 feet. The use of a 50 foot working swath thus gives a 3 to 5 foot overlap on each side which is normally adequate. In some cases, it may be desirable to reduce the working swath width. This will have the effect of increasing the volume applied to each acre. To double the quantity applied per acre, simply fly a 25 foot swath.

As larger nozzle orifices and cores are used, the droplet size will increase. Also, as lower pressures are used the droplet size will increase. These two variables can be altered to produce the correct quantity per acre and the desired droplet size.

An almost perfect consistency in size and distribution of droplets is obtained throughout the entire 55 to 60 foot swath in the use of the Piper sprayer.

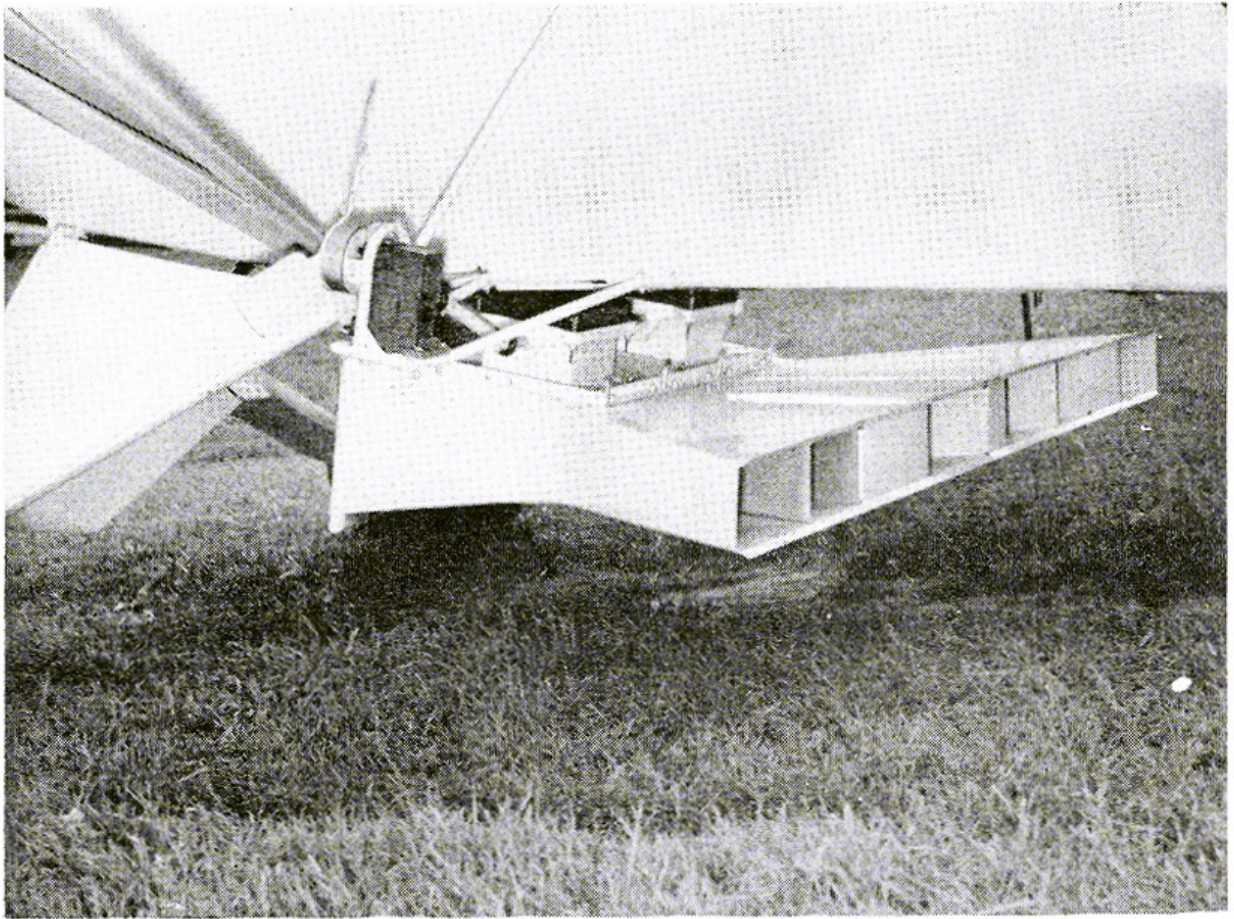

Figure 11

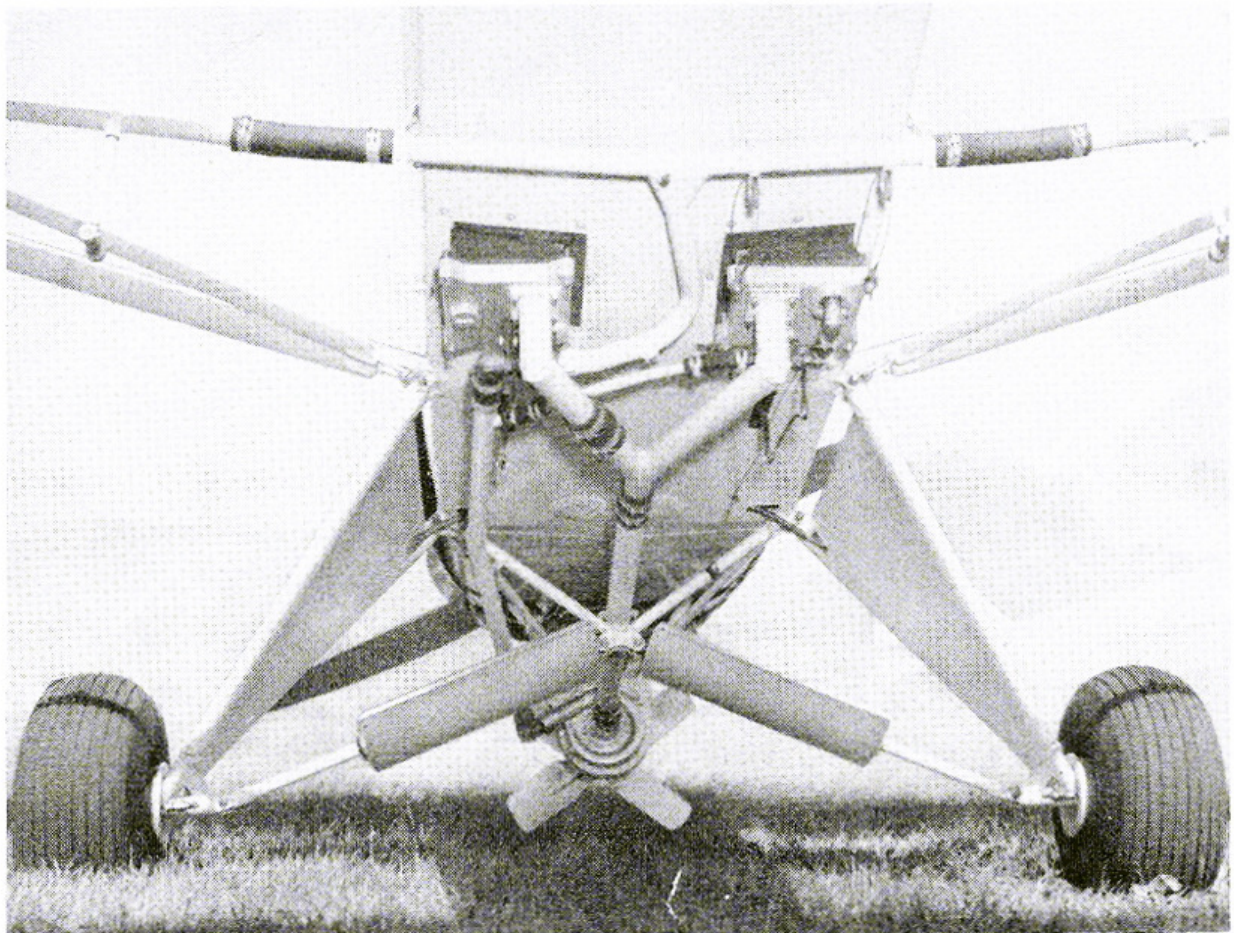

Figure 12

SECTION IV

Operation of the Dust Unit

The dust unit has a capacity of about 600 pounds of the lightest dust, about 800 pounds of standard defoliant, and higher quantities of heavier materials. Output of the dust unit can vary from 5 pounds per acre to over 50 pounds per acre, depending on the weight of material and the setting of the venturi gates. This setting is controlled with the stop under the control handle of the floor.

To pack the dusting hopper completely, it is suggested that a small implement be used to push the dust forward in the tank from the loading door. Otherwise the full capacity cannot be utilized.

Agitation is provided at the hopper exit opening to keep the material moving smoothly. The agitator shaft is supported by 4 sealed roller bearings. The oil in the agitator gear box drive must be kept at the proper level, (at upper pipe plug on face of gear box), using a medium weight worm gear lubricant, to prevent undue gear box wear.

The swath width covered by the dusting unit varies greatly with different materials and conditions and is difficult to measure. Approximately 75 feet is covered in normal application of talc type dust or of defoliant when applied in quantities of 20 pounds per acre or over. No definite recommended working swath width can be given, but it is suggested that operators start with a width of 40 feet and vary it according to conditions. The speed of the airplane when dusting can be varied to fit the circumstances, as with the sprayer. Normal recommended dusting speed is 80 mph. The swath width varies with application of flaps, and the first flap position (about 1/3 flap) is recommended.

SECTION V

Original Installation of the Dispersal Units

The agricultural Super Cub, if obtained without either of the dispersal units installed, can be equipped with these units as follows:

SPRAY UNIT:

1. Remove front and rear seats, including all tubes supporting rear seat.

2. Remove battery and battery box if installed.

3. Remove control cable cover plates from floor of baggage compartment.

(Note: If single stick torque tube is installed, disregard next 6 steps).

4. Remove all metal panels from bottom of fuselage, and top deck panel from top of fuselage.

5. Remove bottom elevator cable from rear and forward through the torque tube horn, as far as mocket under front torque tube bearing.

6. Remove upper elevator cable.

7. Remove torque tube and replace with sprayer type torque tube, making sure that tube is free in its bearings.

8. Install longer top elevator cable through torque tube and connect to front stick stub.

9. Reinstall bottom elevator cable.

10. Remove top deck plate from top of fuselage.

11. Install all tie rods which connect to tank restraining straps—two 30 $\frac{1}{4}$ " rods to front strap, two 10 $\frac{1}{4}$ " rods to bottom front restraining channel, and two 12 $\frac{1}{4}$ " rods to bottom rear restraining channel. Rods are held in place with one nut on each side of stub tube in fuselage.

12. Lower tank into position through top hatch keeping bottom of tank as far aft as possible until top of tank can be pushed forward into position. Then slide bottom of tank forward on floor boards until it drops in place.

13. Adjust tank until tie rod can be inserted through tube in tank, (through grommets at side of fuselage near upper longeron), and tighten nut on end of tie rod.

14. Bolt top of tank to adjacent tubular structure with 8 3/16" bolts and elastic stop nuts.

15. Attach top deck plate to top of tank with 10-32 counter sunk machine screws, inserting rubber gasket between tank and top deck plate. Holes should be punched in gasket flange with an awl through screw holes. Butt joint in gasket should be on forward side of opening to prevent leaks.

16. Attach top deck plate to tubular structure using 8-32 round head machine screws.

17. Install 3 tank restraining straps on ends of tie rods, pulling nuts up snug, but taking care not to pull upper part of tank out of position causing fabric distortions.

18. Attach end of aluminum tie strap between two bottom restraining channels using 6-32 machine screws and elastic stop nuts.

19. Cut out two rectangular grommets in bay between landing gear vees in bottom of fuselage.

20. Remove 4 10-32 round head machine screws in rear floorboards adjacent to slots. (Nuts under floorboards are anchored to fuselage). Place control handle assembly in place, attaching with these 4 screws, but omitting washers.

21. Screw pressure regulating valve into $\frac{1}{2}$ " pipe bushing in left side of tank, after installing connecting $\frac{1}{2}$ " nipple.

22. Install pressure gauge in instrument panel and connect line to $\frac{1}{8}$ " pipe connection at regulating valve. Line is clamped to floorboards with two offset clamps and parker screws.

23. Install liquid quantity gauge along right side of cockpit ahead of door. Restricting fitting, part #13576 must be installed at top tank fitting, with top line leading into fitting. Quantity calibration strip should be screwed to side panels at designated points.

24. Reinstall battery, if any, and cable covers.

25. Replace all belly plates, fitting leather gaskets around holes through which tank projects before replacing plates at this point.

26. Clamp spray system manifold assembly to bottom of tank with clamps, inserting neoprene gaskets between tank and bottom plates.

The Piper Super-Cub

27. Install T shaped line to pressure regulating valve through hole in aluminum belly panel, connecting lower ends of the T to pressure relief shut-off and pump outlet pipe with hose clamps.

28. Remove nuts from Landing Gear Cabane Vee, and Lower Engine Hinge Mount bolts. Install pump mount.

29. Attach pump to mount with four $\frac{1}{4}$ " bolts already located in pump.

30. Connect pump inlet with $1\frac{3}{4}$ " hose and clamp. Connect pump outlet with $1\frac{1}{4}$ " hose and clamps.

31. Attach brake assembly to pump mount with two $\frac{3}{16}$ " bolts, tighten Allen screws.

32. Slide thrust bushing on pump shaft to bear against thrust bearing.

33. Insert key in slot in shaft.

34. Install fan and brake drum. Secure by tightening $\frac{1}{8}$ " Allen screw.

35. Connect brake flexible wire control from brake unit to brake handle in cockpit, ascertaining that brake control is correct.

36. Cut out rectangular inspection openings, two at rear spar on each wing.

37. Install boom support clamps on spars, using $\frac{3}{16}$ " bolt and elastic stop nuts.

38. Attach boom support members with one bolt at each hinge point, securing with heavy safety wire through holes in boom supports.

39. Clamp boom to boom supports with clamps attached to end of supports.

40. Clamp boom support brace to rear lift strut, drilling brace on assembly for 6-32 machine screw. Boom should be lined up fore and aft before drilling.

41. Attach inboard ends of booms with hose and hose clamps.

42. Install nozzles on booms.

43. Reinstall front seat.

44. Install wire cutters on leading edge of landing gear.

DUST UNIT:

1. Install tank and control lever assembly as instructed under Spray Unit installation.

2. Attach duster bottom plate assembly to tank throat using the clamps provided and the two neoprene gaskets.

3. Attach gear box mount to three fittings located on left side of fuselage to the rear of wing lift struts.

4. Install gear box on mount, attaching brake assembly and fan, and connecting drive shaft to agitator universal joint.

5. Connect brake control wire from cockpit handle to brake unit.

6. Adjust gate control arms to provide equal travel of gates.

7. Attach venturi to bottom plate assembly.

SECTION VI

Conversion of the Combination Unit

The Agricultural Super Cub can be obtained with either the dust or spray unit installed, and with the other part of the combination unit accompanying the plane or shipped separately. Changing from one unit to the other requires only a short period once the original installation of the sprayer has been accomplished.

To convert from a Sprayer to a Duster:

1. Remove booms by extracting the two hinge bolts and loosening the inboard hose clamp. Leave boom supports in wings unless permanently converting to duster.
2. Remove fan and brake assembly.
3. Remove pump, loosening two hose clamps and extracting the four mounting bolts.
4. Loosen lower hose clamp at pressure regulating valve in cockpit.
5. Detach rods actuating the shut-off valves at the forward end.
6. Remove clamps which attach the bottom plates to the tank and detach the entire spray system manifold in one assembly.
7. Install duster bottom plate assembly with clamps, with rubber gasket in place on tank.
8. Connect gate actuating rods to control lever arms.
9. Adjust forked ends on actuating rods so that both gates move equally.
10. Bolt venturi to bottom plate assembly.
11. Slide gear box agitator drive shaft into universal joint, then bolt gear box to mount.
12. Attach brake assembly and fan to gear box shaft, making sure that fan rotates without brake drag.
13. Install bolt and elastic stop nut at coupling of universal joint and gear box shaft.

To convert back from duster to sprayer, reverse the above procedure.

SECTION VII

Conversion to Two-Place Model

The PA-18A can be converted from either agricultural version to the two-place model as follows:

1. Remove all parts of the agricultural units which will be undesirable on passenger version. (Spray quantity gauge, pressure gauge, and possibly a few other parts can be left in place).
2. Remove single stick torque tube if dual controls are to be connected. Remove upper elevator cable at same time.
3. Install dual stick torque tube with standard cable and push pull tube between sticks.
4. Install rear safety belt.
5. Install rear seat support tubes and assembly. Install rear seat cushions.
6. Install belly plates to close belly openings.
7. Install top deck frame, part #13257 (replacing the top structure of the tank) on the top deck panel. Reinstall top deck panel on the fuselage.

SECTION VIII

Conversion to Cargo Model

1. Remove all necessary parts of agricultural unit.
2. Retain sprayer type control torque tube and cable.
3. Install floorboard panels.
4. Install belly plates to close belly openings.
5. Install tube between lugs on upper longerons (at top of normal rear seat back location). This tube is a structural member and while it can be removed for loading, must be in place during flight.
6. Reinstall top deck panel with top deck frame attached.

Spray Output Table

Low Volume Unit

1" Simplex Pump

24 Nozzles

NOZZLE NO.	LIQUID PRES. Min. and Max. shown		TOTAL CAPACITY G.P.M.	GALLONS PER ACRE 50 Ft. Swath	
	80 MPH	90 MPH		80 MPH	90 MPH
D3-25 Min. Pres. Only	42	55	7.0 9.0	.88	1.0
D4-25 Min. Pres. Only	40	50	9.52 10.8	1.19	1.20
D4-45	39 68	46 90	11.5 12.2 13.3 13.8	1.43 1.53	1.47 1.53
D4-56	42 75	46 85	16.0 16.7 17.6 18.1	2.0 2.1	2.2 2.26
D8-45	35 62	45 78	25.0 25.5 26.1 26.4	3.1 3.2	2.9 2.9
D12-56	24 43	35 52	60.0 63.0 64.2 66.3	7.5 7.95	7.13 7.37

Installation of 24 Nozzles for 50' Swath

For installation of 24 nozzles, plug every other boom outlet with pipe plug or by installing gaskets in front of orifices of nozzles.

NOTE: Quantities not shown on the tables can be applied by using wider or narrower swaths, by changing nozzle placement, or by using other orifice and core combinations. (See Spraying Systems Bulletin #60).

Spraying Systems chart cannot be used for output figures.

Spray Output Table

High Volume Unit

1" Simplex Pump

46 Nozzles

NOZZLE NO.	LIQUID PRES. Min. and Max. shown		TOTAL CAPACITY G. P. M.	GALLONS PER ACRE 50 Ft. Swath	
	80 MPH	90 MPH		80 MPH	90 MPH
D4-45	34		23.0	2.87	
	67		25.0	3.19	
		43	26.4		2.93
		83	27.2		3.02
D8-45	30		43.0	5.37	
	58		46.1	5.76	
		35	48.0		5.3
		67	51.3		5.8
D12-56	13		70.8	8.35	
			82.5	10.32	
		18	76.3		8.48
		37	89.5		9.94

46 Nozzles in T's in Inboard Outlets

33 Ft. Swath

D12-56	13		70.8	13.4	
	32		82.5	15.5	
		18	76.3		12.83
		37	89.5		15.0

Installation of 46 Nozzles for 50' Swath

Install one nozzle with reducer nipple at each boom outlet.

Installation of 46 Nozzles for 33' Swath

Remove nozzle extension at #1 station on the inboard end of boom, and remove nozzles with reducer nipples from all stations except #3, 6, 9, 12 and 14 counting outboard from #1.

Assemble two nozzles with reducer nipples to each 1/4" pipe tee.

Install tees with 1/4" close nipples in stations #1, 2, 4, 5, 7, 8, 10, 11, and 13.

Install 1/4" pipe plugs in all outboard boom outlets.

